

COMS3100/7100

Introduction to Communications

Lecture 23: Phase-Lock Loop (PLL)

This lecture:

- PLL operation and lock-in
- Linearised PLL model and FM detection
- **Frequency synthesizers**
- **Synchronous detection**

Ref: **Carlson**, Chapter 7.3; **R. E. Best**, “Phase-Locked Loops: theory, design and applications” McGraw Hill, 1984; **J. R. Smith**, “Modern Communication Circuits”, McGraw Hill, 1998

Frequency Synthesizer

- Essential component in communication system for frequency translation

$$S_b = S_a * S_{LO}$$

$$S_B = S_A * S_{LO}$$

- Frequency synthesizer generates the LO signal

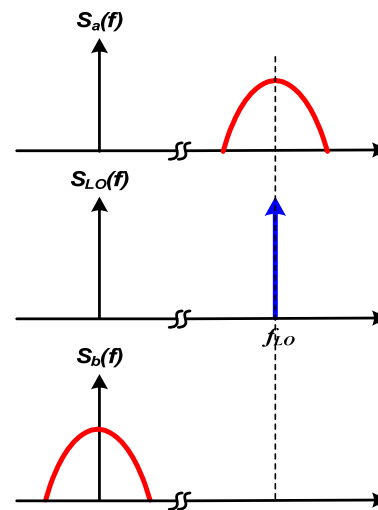
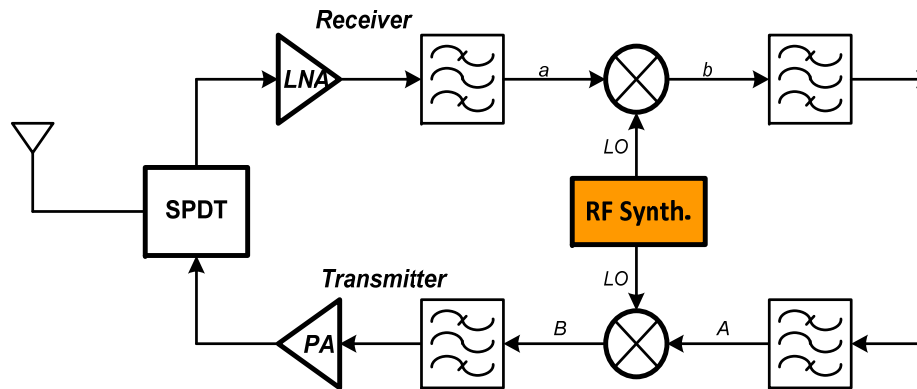

(a) Rx

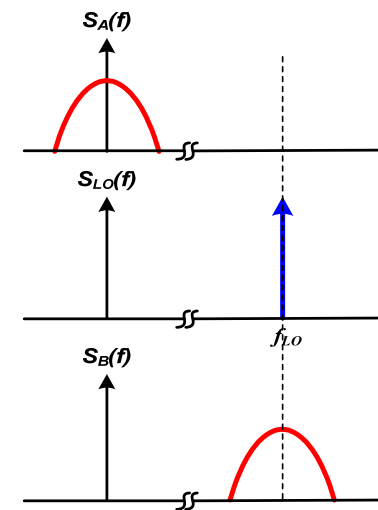

(b) Tx





Direct Frequency Synthesis

- The oldest of the frequency synthesis methods.
- Direct frequency synthesis refers to the generation of new frequencies from one or more reference frequencies by using a combination of harmonic generators, filters, multipliers, dividers, and frequency mixers.
- One method is shown below. The desired frequency is obtained with a filter tuned to a given output frequency. Requires highly selective filters.

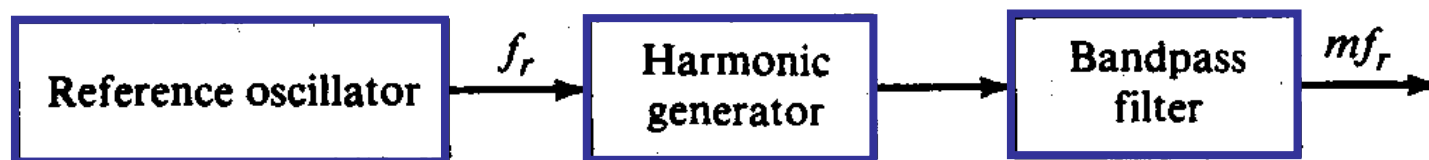

Direct Frequency Synthesis (cont.)

- An alternative approach is to use multiple oscillators.
- Synthesizer shown below generates 99 frequencies from 18 oscillators; BPF selects the higher of the two produced frequencies

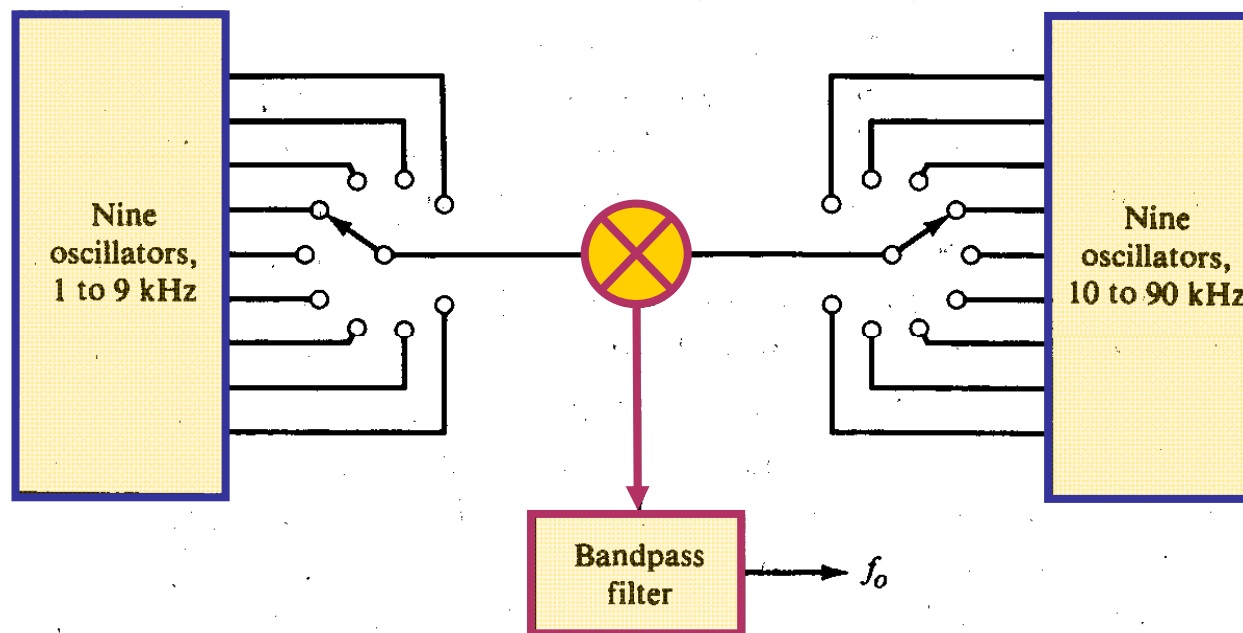

Direct Frequency Synthesis (cont)

- Example of direct synthesis; the new frequency $(2/3)f_0$ is realised from f_0 by using a divide-by-3 circuit and a mixer and BPF.

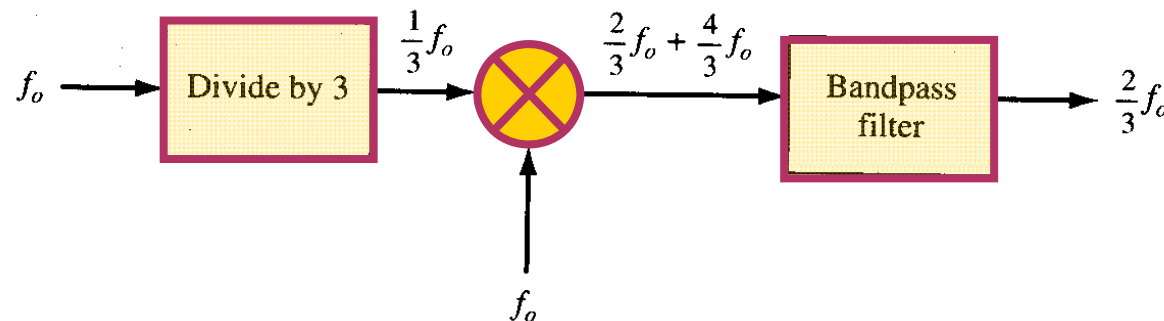

- One of the most critical considerations is the mixing ratio $r = f_1/f_2$
 - If r is too large or too small frequencies are too close and hard to separate by filtering
- The problems associated with direct synthesis are greatly reduced with the frequency synthesis technique that employs a PLL



Frequency synthesis by Phase Lock

- Basic FS-PLL architecture

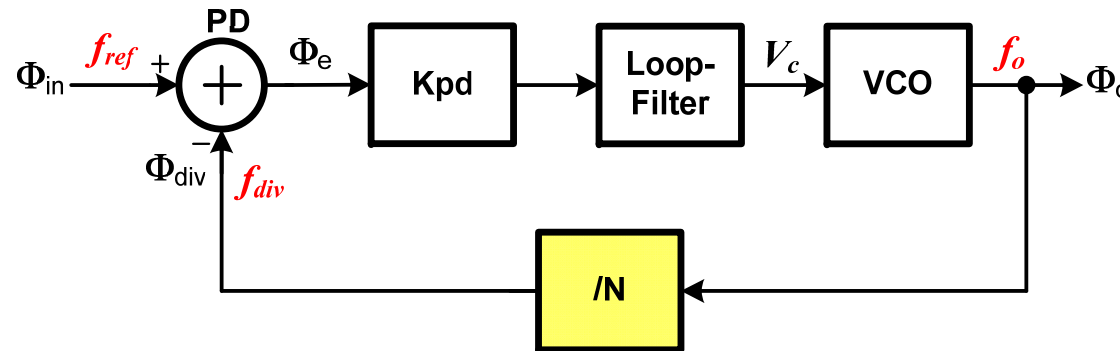

- What's PLL-based Frequency Synthesizer?

- $f_o = N * f_{ref}$
- f_{ref} : reference frequency, typically from a crystal oscillator (XO).
- Sensitive to loop parameters (loop-gain, phase-margin, loop BW, etc) due to the negative feedback loop.
- Loop gain proportional to $1/N$

Frequency Synthesizer PLL

- Why use PLL as a frequency synthesizer?
 - As a local oscillator with a high accuracy and purity.
 - To translate the frequency accuracy of a high quality signal source to a tunable signal source.
 - To translate the noise characteristics of a high quality signal source to a lower quality signal source.
- Design Parameters :
 - Frequency accuracy
 - Phase noise (in-band / out-of-band)
 - Reference / Fractional spurs
 - Settling time (or Channel switching time / Lock-up time)
 - Input sensitivity
 - Power consumption
 - Size, cost, etc



Transfer function of the PLL based frequency synthesizer

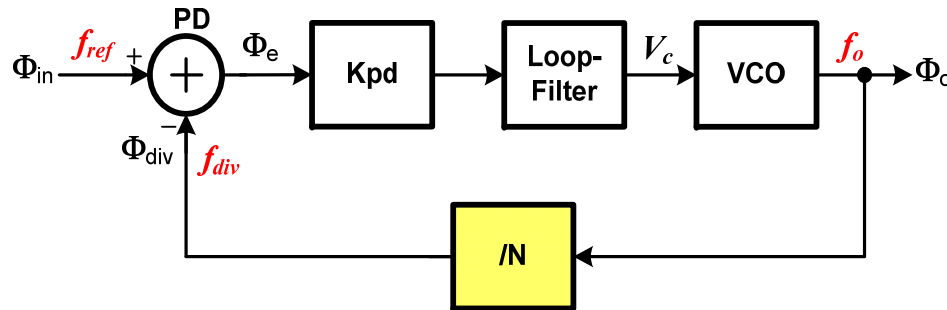

$$\frac{\theta_o(s)}{\theta_r(s)} = \frac{K_d K_o F(s)/s}{1 + K_d K_o F(s)/(Ns)} = \frac{G(s)}{1 + G(s)/N} \quad (8.4)$$

The same transfer function relates the input and output frequencies $f_r(s)$ and $f_o(s)$.

If no low-pass filter is used, the transfer function is

$$\frac{\theta_o}{\theta_r} = \frac{K_d K_o}{s + K_d K_o/N} = \frac{NK_v}{s + K_v}$$

which is equivalent to the transfer function of a simple low-pass filter with a dc gain of N and a bandwidth equal to K_v , where

$$K_v = \frac{K_d K_o}{N}$$



PLL based frequency synthesizer – an Example

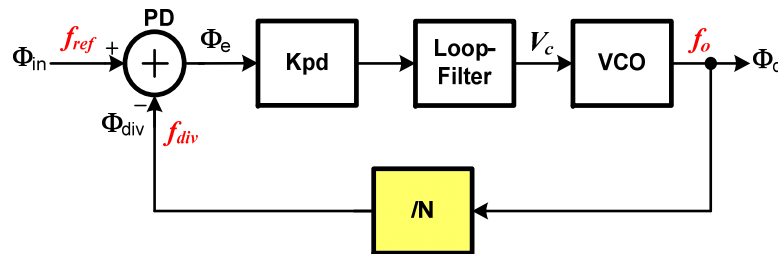

A frequency synthesizer uses a PLL to synthesize a 1-MHz signal from a 25-kHz reference frequency. To realize an output frequency of 1 MHz, a division of

$$N = \frac{10^6}{25 \times 10^3} = 40$$

must be included in the feedback path. If no filtering is included, the closed-loop transfer function will be

$$\frac{\theta_o}{\theta_r} = \frac{K_d K_o / s}{1 + K_d K_o / (sN)} = \frac{K_d K_o}{s + K_d K_o / N}$$

A typical value for K_d is 2 V/rad, and a typical value for the VCO gain factor K_o (for a 1-MHz VCO) is 100 Hz/V. With these values the closed-loop transfer function is

$$\frac{\theta_o}{\theta_r} = \frac{(2 \times 100)2\pi}{s + (2 \times 100 \times 2\pi)/40}$$

The synthesizer bandwidth will be $(2 \times 100)/40$, or 5 Hz.



Effect of Reference Frequency on Loop Performance

- To obtain fine frequency resolution, the reference frequency must be small. This also requires large N values, then causing large variations in the open-loop gain
- Secondly the loop bandwidth needs to be less than the reference frequency because the LPF must filter out the reference frequency and its harmonics present at the PD output.
- Finally the effect of noise introduced in the VCO becomes pronounced. Three main sources of noise are
 - Noise of the reference signal - $\Phi_{n,ref}$
 - Noise created by the phase detector - $\Phi_{n,PD}$
 - Noise introduced by the VCO - $\Phi_{n,VCO}$

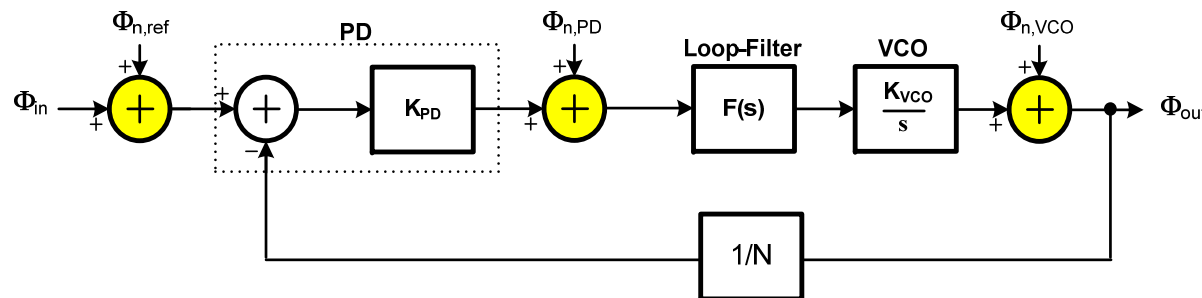

Noise Characteristics of the PLL synthesizer

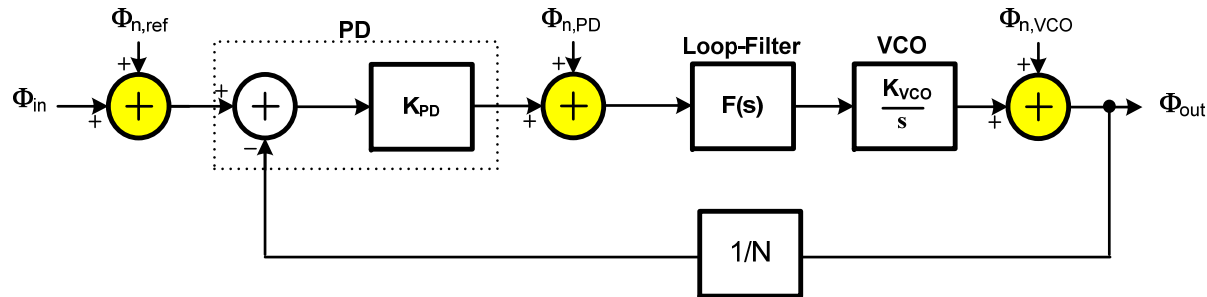

$$\frac{\Phi_{\text{out}}}{\Phi_{\text{n,ref}}} = \frac{G(s)}{1 + G(s)/N} = H(s)$$

$$\frac{\Phi_{\text{out}}}{\Phi_{\text{n,PD}}} = \frac{1}{K_{PD}} \cdot \frac{G(s)}{1 + G(s)/N} = \frac{1}{K_{PD}} \cdot H(s)$$

$$\frac{\Phi_{\text{out}}}{\Phi_{\text{n,VCO}}} = \frac{1}{1 + G(s)/N}$$

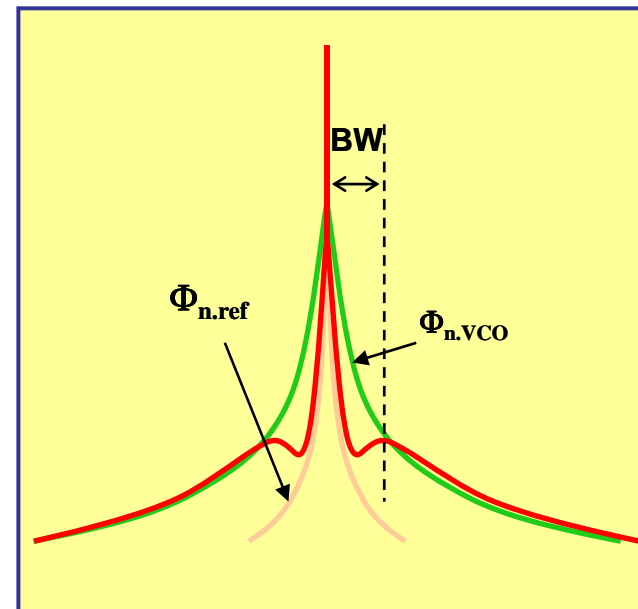

- PLL acts as a **lowpass filter** for the phase noise arising in the reference signal and the phase detector, and as a **high-pass filter** for the phase noise originating in the VCO



Phase Noise and Jitter in PLL synthesizers

Time Domain
Jitter



Frequency Domain
Phase Noise

- Cycle-to-cycle Jitter
: two consecutive pulses
- Peak-to-peak Jitter
- Spurious Tone
- From f_r

$$\text{dBc/Hz} = \text{dBm/Hz} - \text{dBm}(\text{carrier}) = 10 \log \frac{V^2/\text{Hz}}{V_o^2/2},$$

$$\text{dBm/Hz} = 10 \log \frac{V^2/\text{Hz}}{50\Omega \times 1\text{mW}},$$

$$\text{dBm}(\text{carrier}) = 10 \log \frac{V_o^2/2}{50\Omega \times 1\text{mW}}$$

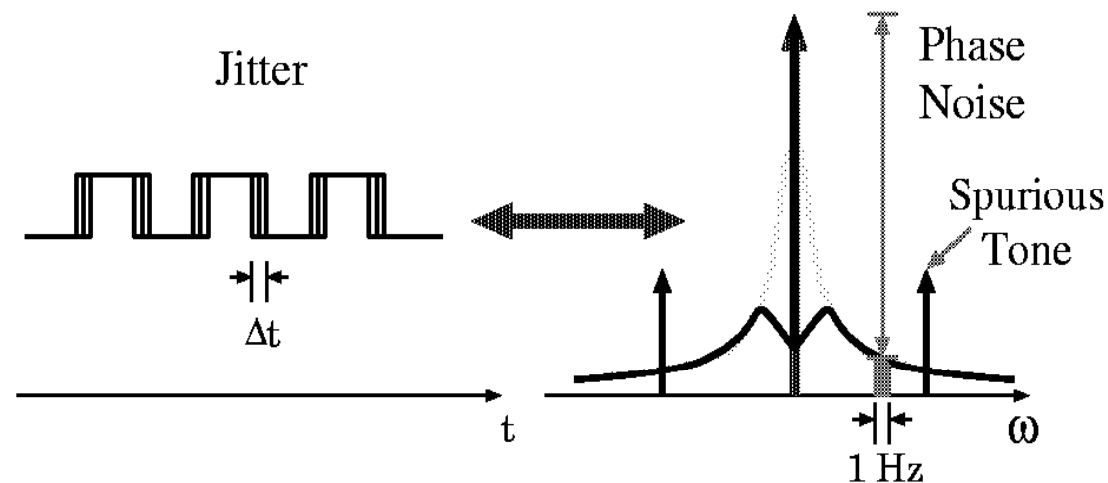

Frequency Domain Analysis (cont.)

- To reduce phase noise or jitter
 - VCO noise dominated system : Increase the loop bandwidth
 - Reference XO/PD noise dominated system : Decrease the loop bandwidth.

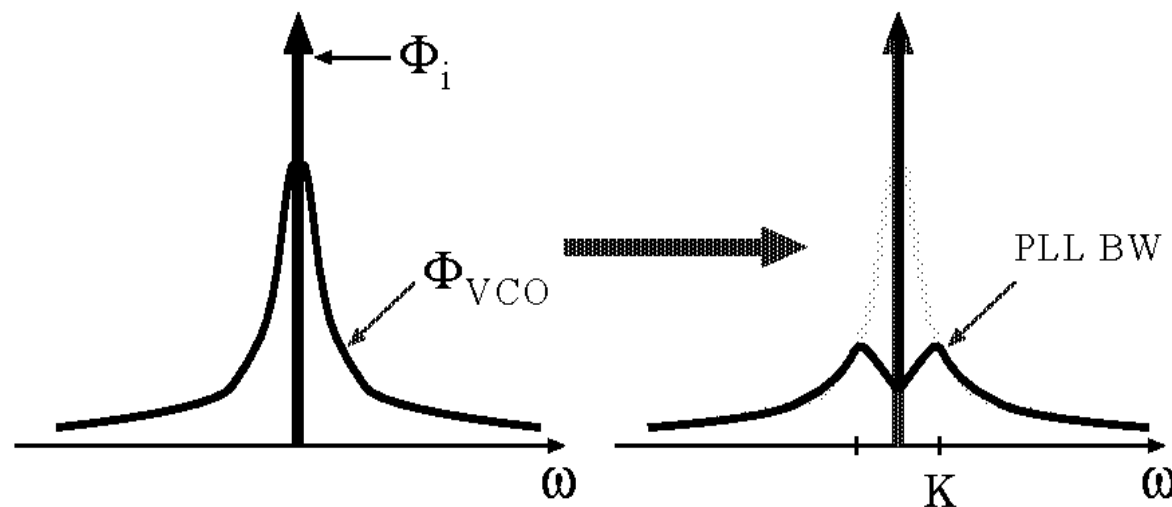

Variable modulus dividers and the role of prescalers

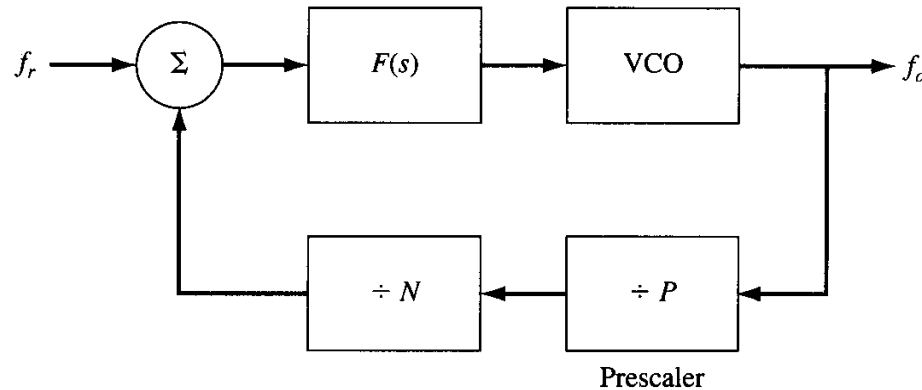

$$f_r = \frac{f_o}{NP}$$

$$f_o = N(Pf_r)$$

$$f_o = P \left(N_o + \frac{AQ}{P} \right) f_r = PN_o f_r + AQ f_r$$

Variable modulus dividers and the role of prescalers

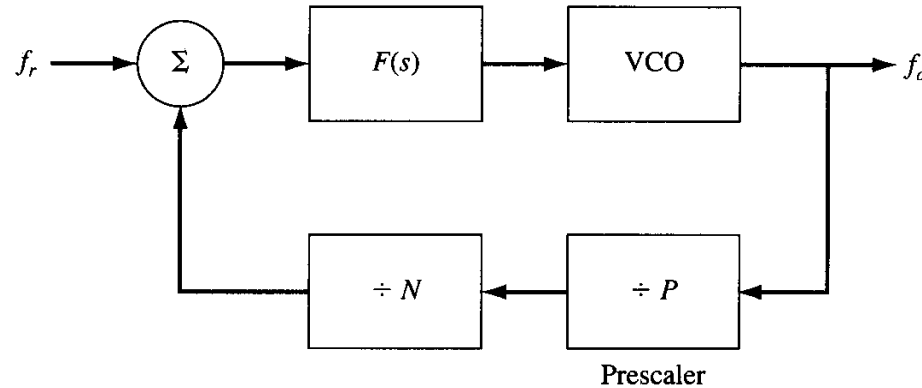

$$f_r = \frac{f_o}{NP}$$

$$f_o = N(Pf_r)$$

$$f_o = P \left(N_o + \frac{AQ}{P} \right) f_r = PN_o f_r + AQ f_r$$

$$f_o = (N_o P + AQ - \boxed{AP + AP}) f_r = [P(N_o - A) + (P + Q)A] f_r$$

Example 1 (form Carlson):
Frequency synthesizer with fixed and adjustable outputs

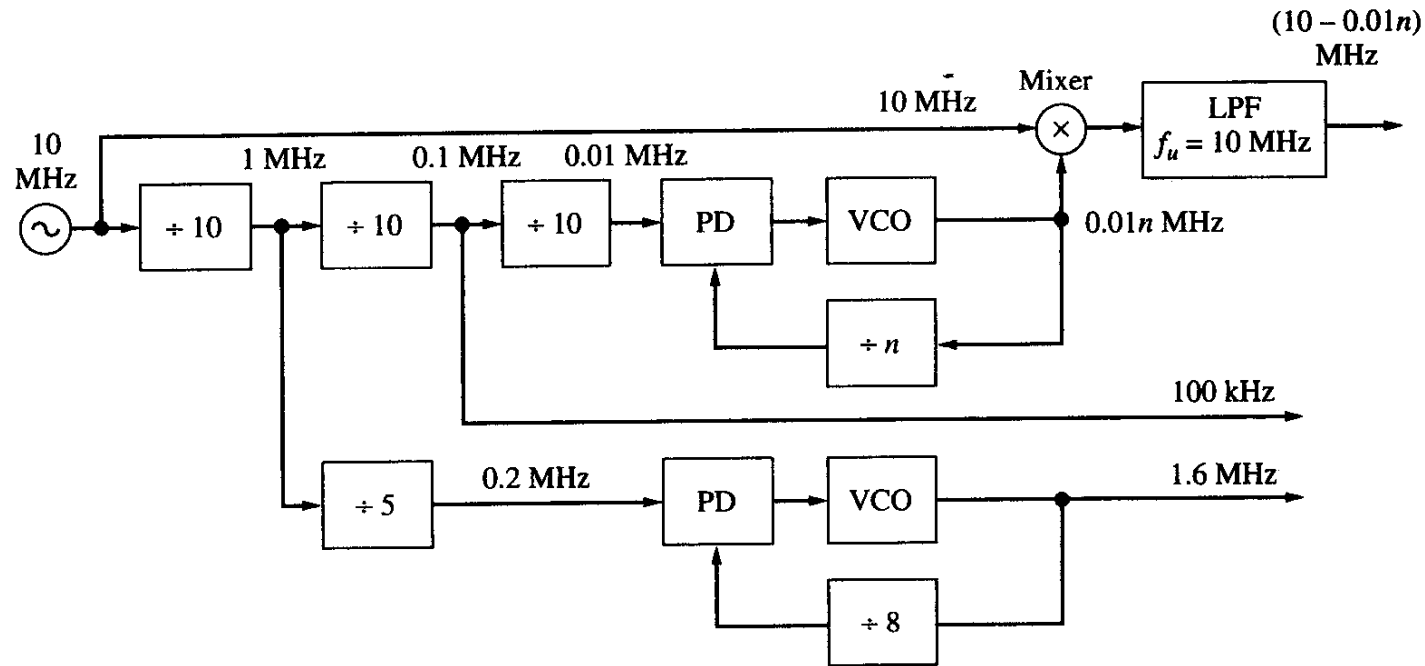

Example 2: Frequency synthesizer with fixed and adjustable outputs for the GSM base-station receiver

- In addition to the tunable RF LO, the receiver section also uses a fixed IF (in the example shown this is 240 MHz). Even though frequency tuning is not needed on this IF, the PLL technique is still used. The reason for this is that it is an affordable way of using the stable system reference frequency to produce the high frequency IF signal.

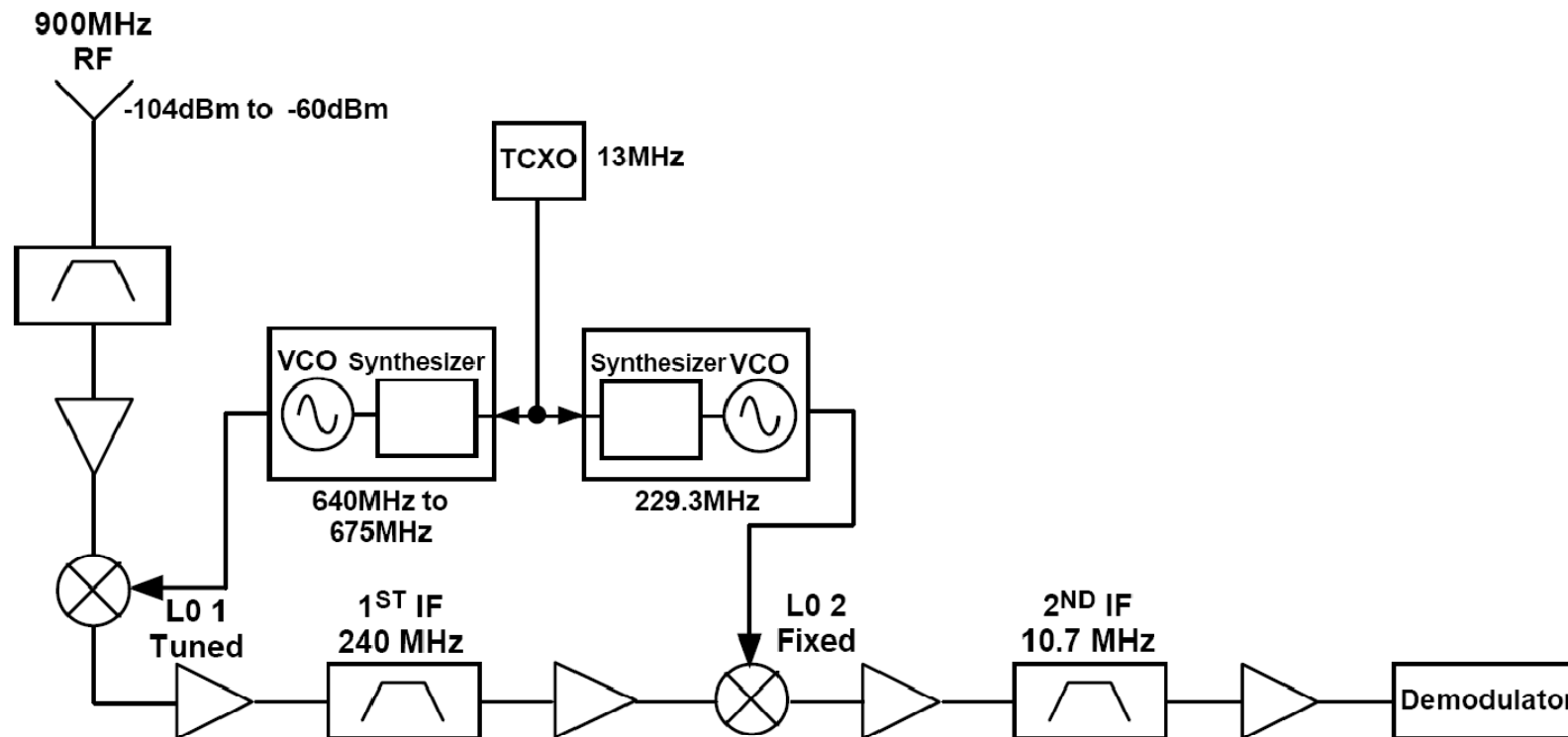

CW Source Specifications: Spectral Purity

- Phase Noise
- Residual FM
- Spurious

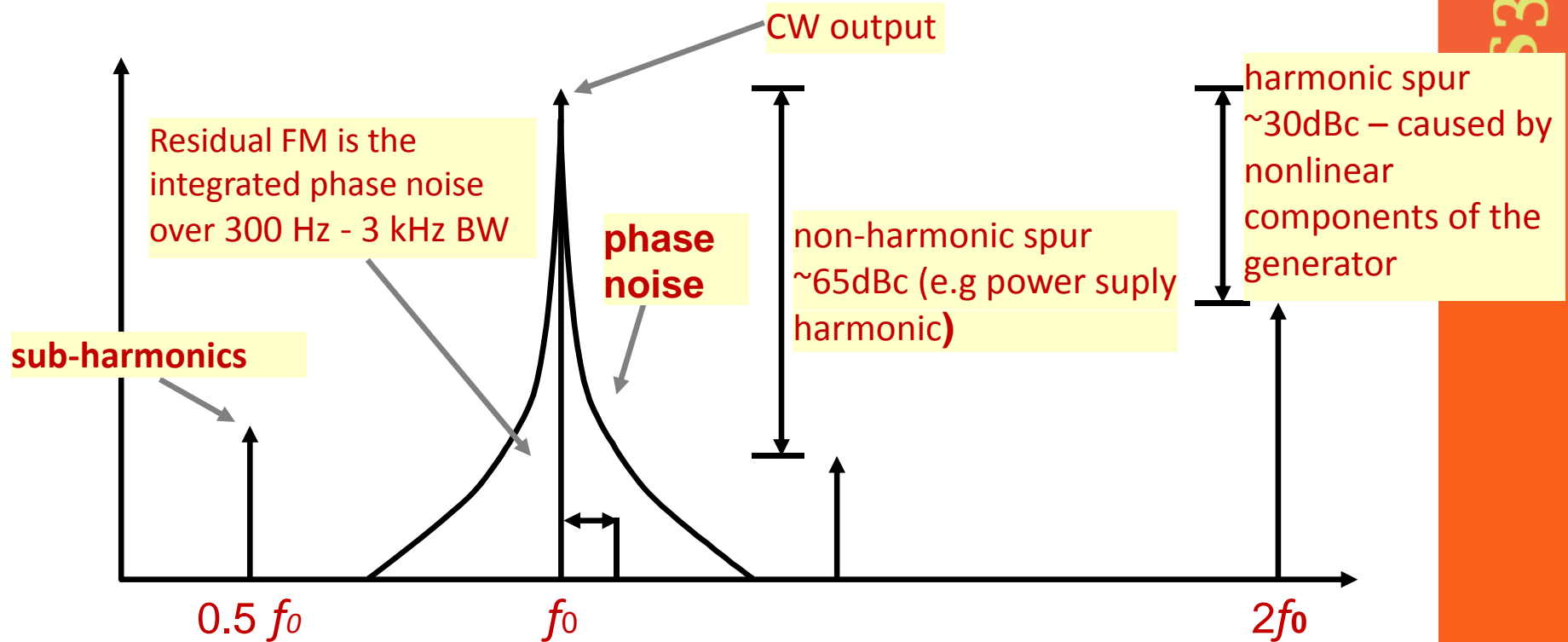

CW Source Specifications: Spectral Purity - Phase Noise

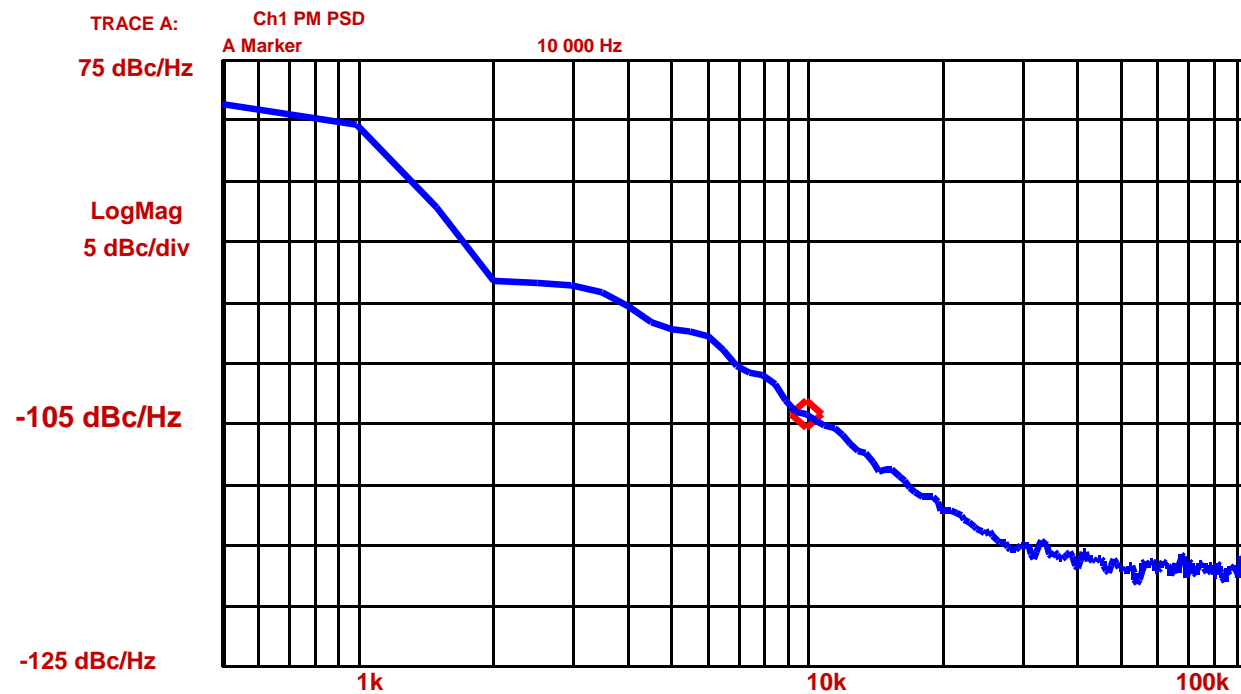
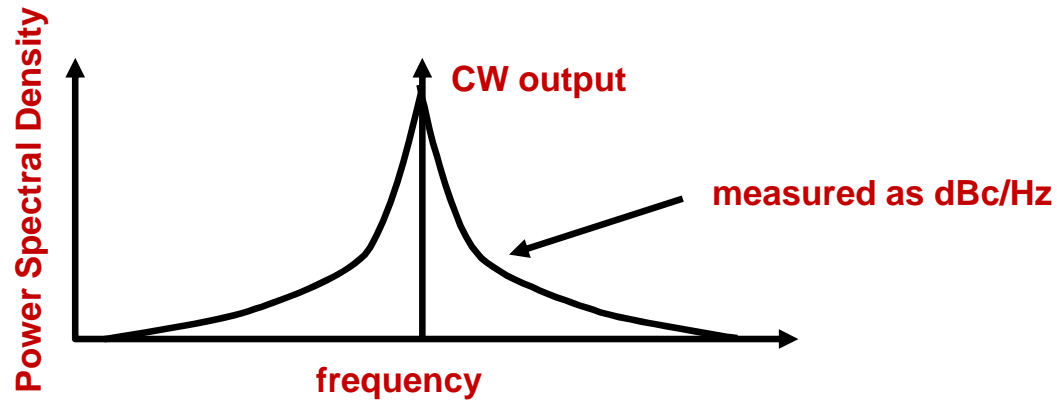

PLL based RF CW Source Block Diagram

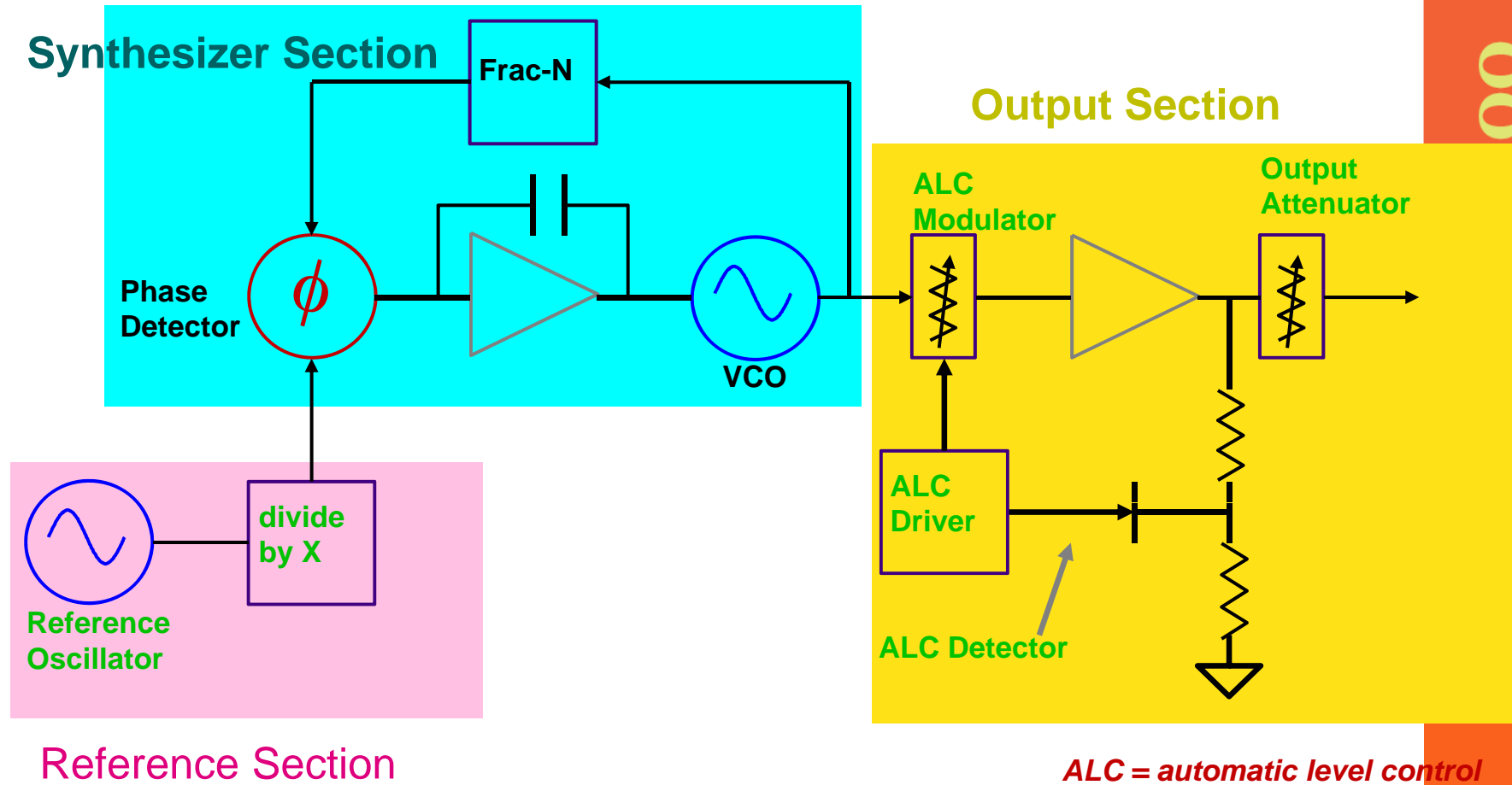

RF CW Source Block Diagram Reference Section

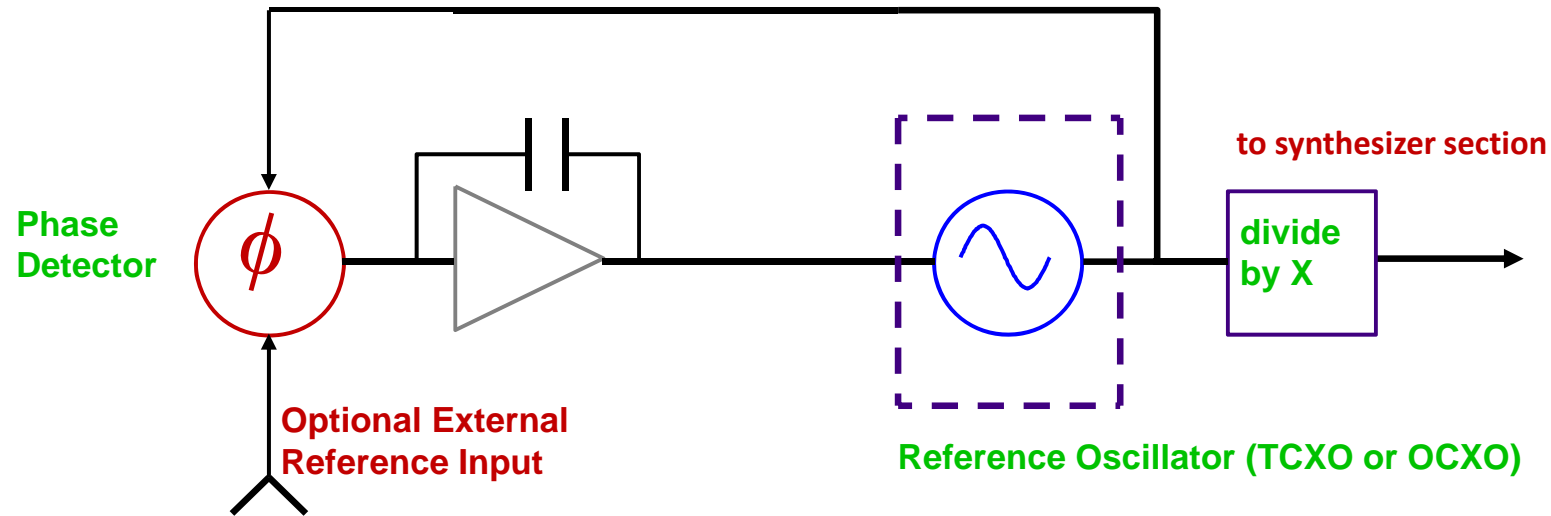

	TCXO	OCXO
Aging Rate	+/- 2ppm/year	+/- 0.1 ppm /year
Temp.	+/- 1ppm	+/- 0.01 ppm
Line Voltage	+/- 0.5ppm	+/- 0.001 ppm

Temperature Compensated XO
Oven Controlled XO

RF CW Source Block Diagram: Synthesizer Section

...produces accurate, clean signals

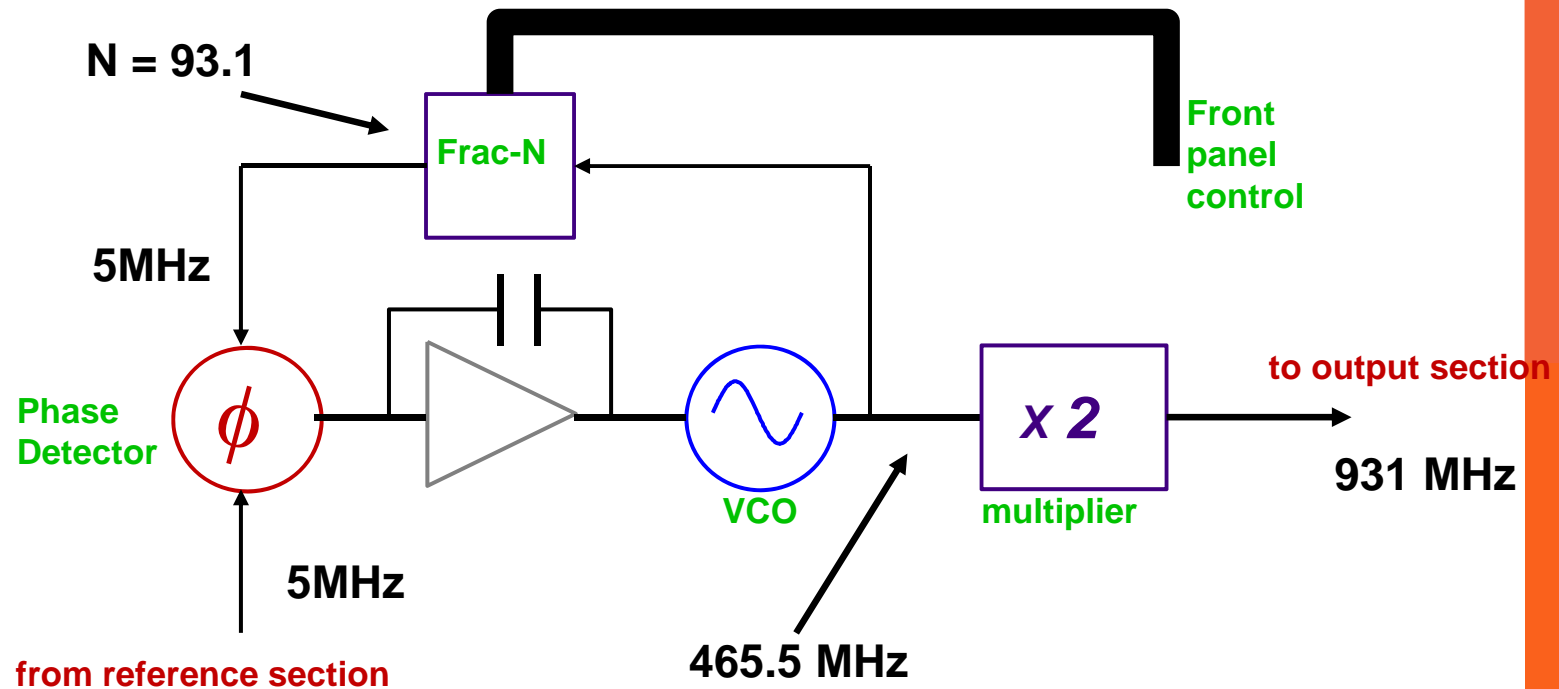



Detecting DSB using PLL

- An important application for PLLs is in **synchronization** of receiver local oscillator for synchronous detection
- In the **Costas PLL** (below) two phase discriminators are used to:
 - cancel out DSB modulation $x(t)$ in the driving signal
 - synchronize the output frequency to the center frequency of the DSB spectra (the suppressed carrier)
 - to detect the DSB signal

PD: phase detector (=multiply+LPF)

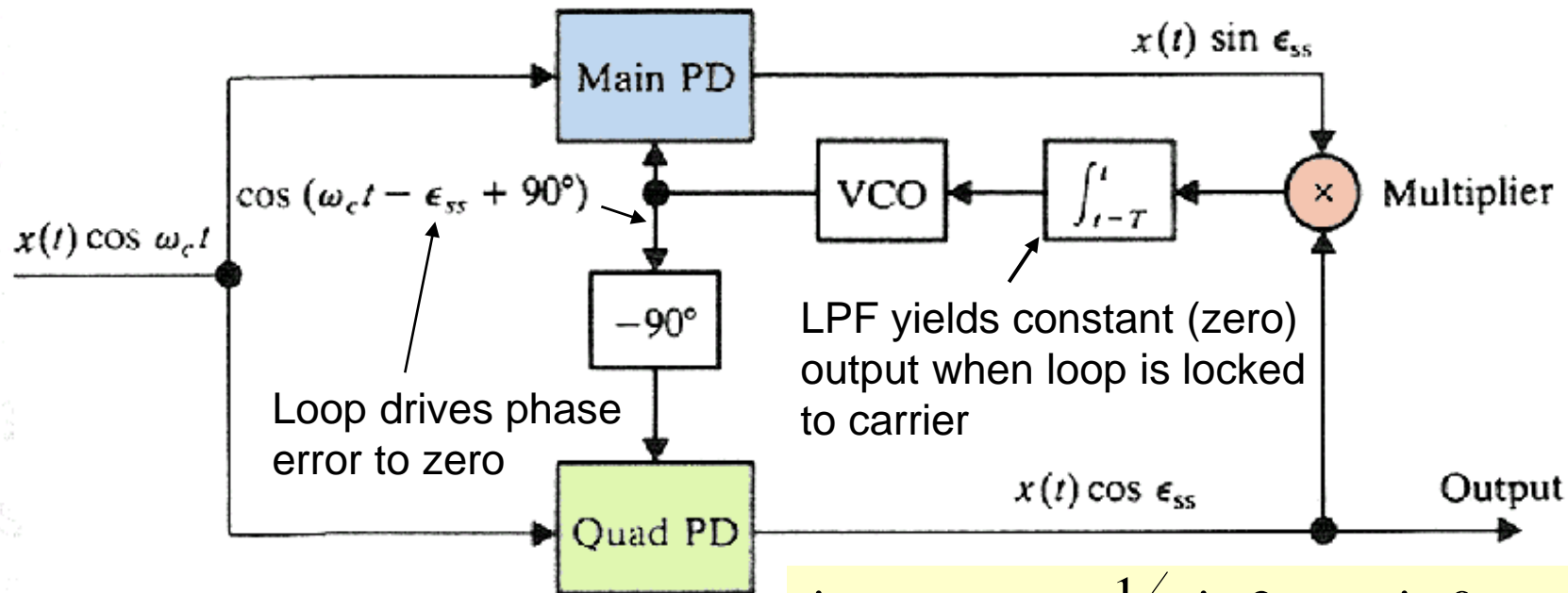

$$\sin \epsilon_{ss} \cos \epsilon_{ss} = \frac{1}{2} \sin 2\epsilon_{ss} + \sin 0 \approx \epsilon_{ss}$$

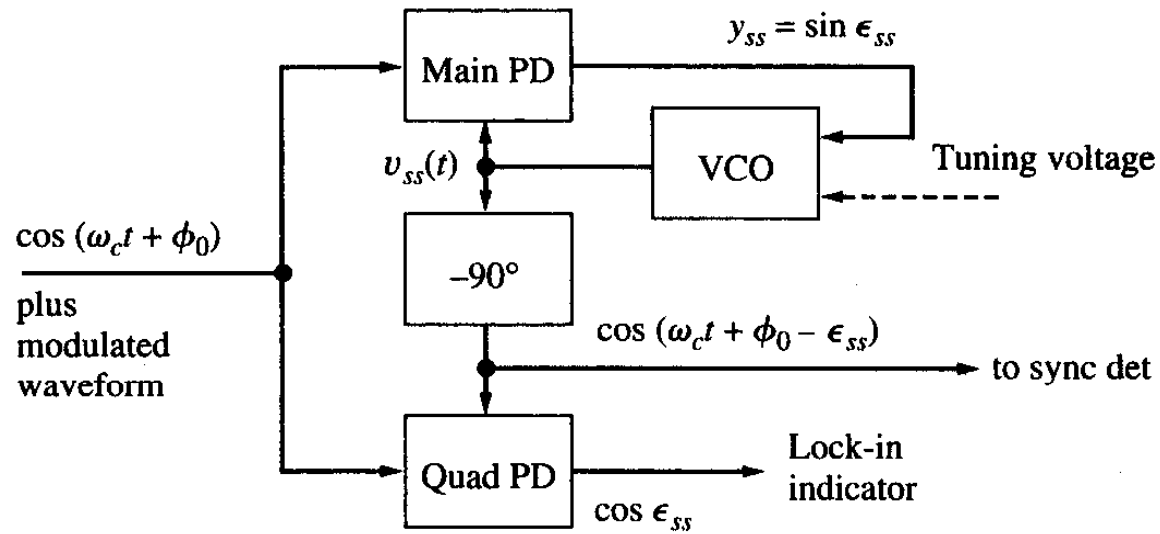

Figure 7.3-3 PLL pilot filter with two phase discriminators (PD).

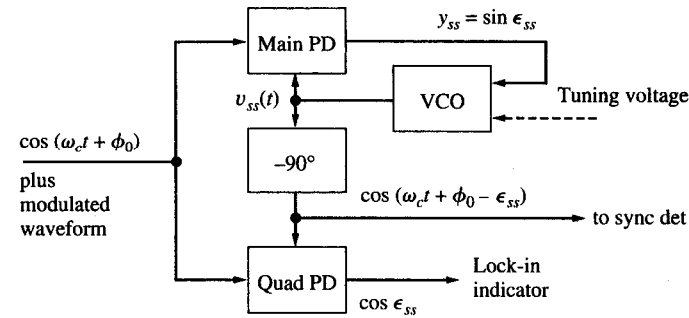

Figure 7.3-3 PLL pilot filter with two phase discriminators (PD).

$$y_{ss} \approx T \langle x^2(t) \rangle \sin \epsilon_{ss} \cos \epsilon_{ss} = \frac{T}{2} S_x \sin 2\epsilon_{ss}$$

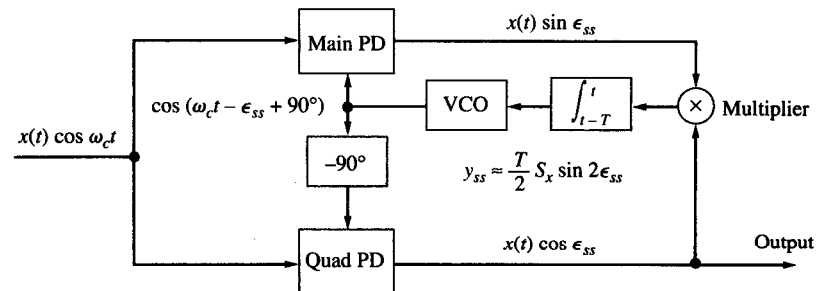

Figure 7.3-4 Costas PLL system for synchronous detection.

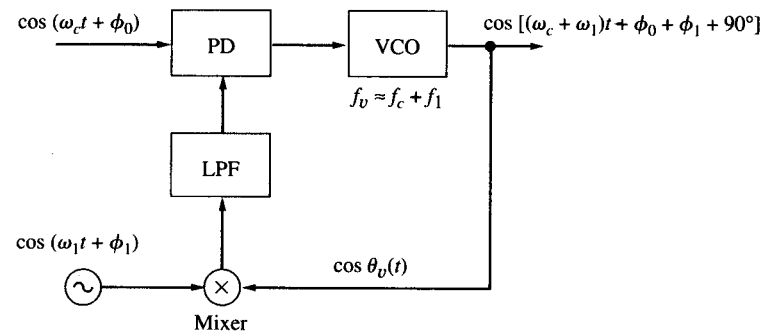

Figure 7.3-5 Frequency-offset loop.

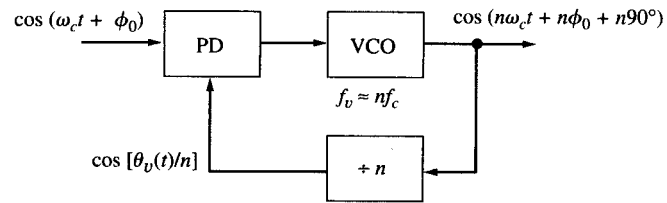

Figure 7.3-6 PLL frequency multiplier.