

# Understanding the Impacts of Moisture and Thermal Ageing on Transformer's Insulation by Dielectric Response and Molecular Weight Measurements

**T. K. Saha**

School of Information Technology and Electrical Engineering  
University of Queensland, St Lucia, Qld - 4072  
Australia

and **P. Purkait**

Department of Electrical Engineering  
Haldia Institute of Technology  
Haldia, Midnapore (E) – 721657, WB, India

## ABSTRACT

Properties of oil and paper in a transformer degrade primarily due to thermal ageing and moisture ingress. Dielectric diagnostic tests, such as Recovery Voltage (RV), and Polarizations and Depolarization Current (PDC) measurement are currently being explored as potential tools for insulation condition assessment. A modern chemical analysis tool for paper molecular weight (MW) measurement, Gel Permeation Chromatography (GPC) or the more accurately described Size Exclusion Chromatography (SEC) promises to be useful in assessing ageing condition. However, the issue of separately assessing the impacts of ageing and moisture on oil and paper has been a key issue for many years. In the current research project, a series of experiments have been performed under controlled laboratory conditions with preset moisture content, and at controlled high temperature ageing. Whereas RV and PDC measurement results were found to be more sensitive to the moisture content of the oil and paper insulation, the MW distribution measurement by SEC provided a trend of insulation thermal ageing. This paper first provides a brief description of RVM, PDC and SEC procedures followed by a description of the experimental techniques adopted. Results are then analysed with the view of separately understanding the impacts of thermal ageing and moisture on the condition of oil and paper insulation in a transformer.

Index Terms — Condition monitoring, gel permeation chromatography, moisture content, moisture related degradation, molecular weight, polarization and depolarization current, return voltage, size exclusion chromatography, thermal ageing, transformer condition assessment.

## 1 INTRODUCTION

THE insulation system in a power transformer consists of cellulosic materials (paper and pressboard) and processed mineral oil. Cellulose insulation materials have been proven to have desirable chemical and physical properties for use as electrical insulators, but they degrade as the materials age. Therefore, the degradation of the cellulosic materials is an important factor in determining the remaining life of a transformer. Typical operating temperatures for power transformers lie between 65 to 100 °C. At these temperatures, the

insulation materials undergo slow ageing with concurrent loss in mechanical and electrical properties [1]. The insulation properties can also degrade due to the presence of moisture in the oil-paper system. This moisture may be generated inside the transformer due to degradation of the oil-paper insulation or there may be ingress of moisture due to free breathing arrangements. Much effort has been devoted over the years for accurately assessing condition of the insulation in terms of moisture content and ageing status – and thereby possibly predicting its useful remaining life.

In recent years, several research groups have reported applications of non-destructive dielectric measurement

techniques for insulation condition assessment. These include Recovery Voltage Measurement (RVM) [2-4], and more recently, the Polarization and Depolarization Current (PDC) measurement technique [5-8] in time domain and Frequency Domain Spectroscopy (FDS) [9-10]. These studies have shown that dielectric response measurements could be used as an effective tool for transformer condition assessment. However, it has been revealed that moisture content has a dominant influence on nearly all electrical based diagnostic techniques for assessing the condition of insulation, and indeed, masks their capability to determine the presence and extent of ageing by-products of the cellulosic insulation [11]. There are two main reasons why electrical techniques mostly do not provide good measures of the ageing of cellulosic insulation. The first, as already mentioned is the dominant effect of moisture on most electrical properties. The second is that the electrical properties of the oil impregnated paper and pressboard are probably more a complex function of oil and cellulose. Therefore, electrical techniques are not very sensitive measures of the extent of ageing of paper/pressboard insulation [11].

The thermal ageing process of paper can be monitored by measuring properties such as the tensile strength, degree of polymerisation, furan content in oil, etc. Many initial works are based on the measurement of tensile strength and considering it as a criterion for determining the remaining life of insulation. Cellulose is a linear polymer of glucose molecules, which are connected together through the glycosidic bond. The length of the cellulose chain is measured in terms of the Degree of Polymerisation (DP) - which is the average number of glucose units per cellulose molecule. Early studies, reported in the literature, include the work of Shroff et al [12], who measured changes in the DP of paper with time, and in conjunction with Burton and others [13] empirically related the DP to the Furfural concentration in the oil. In many studies reported in the literature, viscosity measurements have been used to characterise the molecular weight change in the polymer after degradation. However, Molecular Weight studies by single-point viscosity measurements are of limited value when dealing with a complex blend such as Kraft paper, particularly in cases where the molecular weight distribution of the polymer changes significantly as the degradation proceeds. In these instances, Size Exclusion Chromatography (SEC) is more useful than the viscosity method, because it provides information about the changes in molecular weight distribution [14-20].

Authors in [21-23] proposed the use of spectroscopy together with multivariate statistical analysis (MVSA). The developed MVSA provides a powerful non-destructive evaluation of the condition of paper. From initial feasibility studies, they have developed a simple, portable system, known as TRANSPEC using fiber-optics and broad-band spectroscopy that can measure the degree of polymerization of various aged transformer papers to a precision of approximately 30 DP units with a spatial resolution of 14 mm. The system can also measure the chemical composition and condition of the insulating mineral oil. The system also promised to separate the oil and paper information

for measurement of DP in oil-wetted paper samples. In addition, the system has been shown to be capable of the prediction of both oil and water content of paper to a high accuracy, and is also capable of identifying and quantifying different water species.

Authors in [24] studied the usability of frequency domain spectroscopy for detecting moisture and the state of aging of pressboard and paper insulation in transformers. The method seems to be a feasible method for measuring the average moisture content in a transformer winding. It is also sensitive to other aging by-products like low molecular weight acids. The research group at the University of Queensland has been involved over the last 15 years in development and application of different dielectric (RVM and PDC) and chemical (SEC) testing techniques for assessment of oil-paper insulation condition. Accelerated ageing paper samples and samples from failed transformers were tested using the RVM and SEC techniques [1]. Results from other sets of accelerated ageing experiments with controlled conditions of moisture and oxygen/nitrogen environments were reported in [25-26]. Results of dielectric and chemical tests on a series of accelerated ageing samples at 115 °C were presented in [27]. An attempt was made to correlate between the dielectric and chemical (SEC) test results. The question of separately identifying the effects of moisture and ageing condition of the paper remains unanswered.

This paper looks at addressing this key issue of separation of moisture and ageing effects on the condition of the insulation. Brief overviews of dielectric testing techniques (RVM and PDC) and chemical techniques for molecular weight measurement by SEC are presented at the beginning of this paper. Results of dielectric tests and SEC tests on recently completed accelerated aged paper samples at different controlled moisture contents are then discussed. Finally, a comparative study between the dielectric and SEC test results is made with a view to address the issue of identifying the individual effects of thermal ageing and moisture content of the paper insulation.

## 2 DIELECTRIC RESPONSE MEASUREMENTS IN TIME DOMAIN

When an external step voltage  $U(t)$  given by equation (1) is applied to an initially relaxed insulation test object, then the polarization current is given by equation (2).

$$U(t) = \begin{cases} 0 & t < 0 \\ U_0 & 0 \leq t \leq t_1 \\ 0 & t > t_1 \end{cases} \quad (1)$$

Where  $U_0$  is the magnitude of the step voltage, and  $t_1$  is the time during which the voltage has been applied to the test object.

$$i_{pol}(t) = C_0 U_0 \left[ \frac{\sigma}{\epsilon_0} + f(t) \right] \quad (2)$$

where  $\sigma$  is the dc conductivity of the composite oil/paper insulation system,  $\epsilon_0$  is the vacuum permittivity,  $C_0$  is the

geometric capacitance (measured capacitance at or near power frequency, divided by the relative permittivity  $\epsilon_r$  of the insulation arrangement at power frequency). The response function  $f(t)$  describes the fundamental memory property of the dielectric system and can provide significant information about the insulating material [9]. The function  $f(t)$  can be determined experimentally as the response of the dielectric to a step-function charging field [9].

Once the step voltage is turned off and the insulation is short circuited, a depolarization current flows through ground. The magnitude of the depolarization current is expressed as:

$$i_{d\text{epol}}(t) = C_0 U_0 [f(t) - f(t + t_1)] \quad (3)$$

After a predetermined period of discharging (for example, half the period of charging), the two terminals of the insulation are open circuited and a voltmeter is connected between them. The remaining charge inside the insulation system due to incomplete discharging will give rise to the so-called recovery or return voltage as shown in Figure 1. The peak recovery voltage and the corresponding time are recorded. This process of charging, discharging and measuring the recovery voltage is continued for gradually increasing values of charging times. The charging/discharging time ratio is chosen to be two (2.0) for the measurement procedure followed in this work. The peaks of the recovery voltages from the individual cycles and their corresponding charging times are plotted to obtain the so-called RV spectra. The time to reach the peak of this RV spectrum (not the corresponding charging time that is used as X-axis variable in the plot) is called the central time constant (CTC) – which is often used as an indication of the insulation condition.

During PDC measurement, the insulation is simply charged and discharged for longer durations of time (typically 10,000 s each) and the corresponding polarization and depolarization currents are recorded. The magnitudes of these currents and oil and paper conductivities calculated from them can give information about the condition of the insulation. Figure 1 summarizes the two dielectric response measurements in time domain (RVM and PDC). Theoretically, Figure 1 should show infinite charging current impulses at  $t=0$  and  $t=t_1$  because of ideal voltage step functions. In practice however, these initial transients are not recorded.

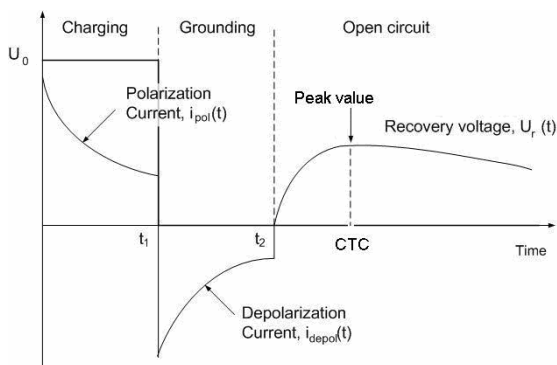

Figure 1. Time domain dielectric measurements

Details of first version of the measurement system are described in [6, 27]. Several new features have been added to the latest version of the RV and PDC measuring equipment developed by the research group at the School of Information Technology and Electrical Engineering, University of Queensland. Figure 2 shows the schematic diagram of the testing equipment.

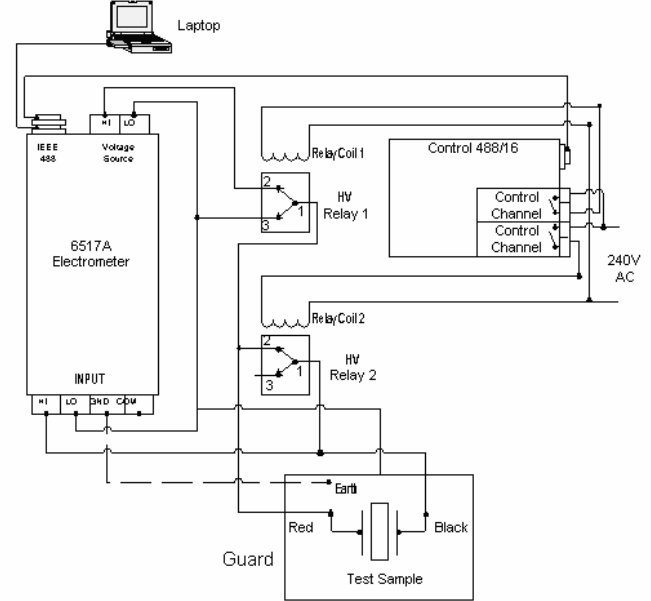

Figure 2. Schematic diagram of the dielectric response measuring equipment

A screening arrangement is used to protect the measured signal from stray capacitive charging currents and noise/interference during polarization and depolarization current measurements.

For calculation of oil and paper conductivities from the polarization current, it is essential to model the oil-paper insulation system with consideration of its geometric arrangement as shown in Figure 3. Such an arrangement has proved to be effective for simulation and modeling of dielectric response in multilayer oil-paper insulation systems [28]. Each material is characterized by its conductivity and permittivity along with the composite dielectric response function  $f(t)$ .

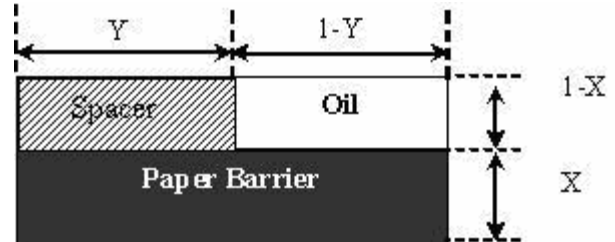

Figure 3. Geometric arrangement of oil and paper/spacer used for modeling

$X$  is the relative amount of paper in the main duct and  $Y$  is the relative amount of spacer coverage in the composite system. Values of  $X$  and  $Y$  are of the order of 20% to 50% for most common transformer insulation arrangements.

In such an arrangement of oil duct, spacer and paper barrier insulation, the expression for the effective permittivity of the insulation system can be written as:

$$\varepsilon_r = \frac{Y}{\frac{1-X}{\varepsilon_{sp}} + \frac{X}{\varepsilon_p}} + \frac{1-Y}{\frac{1-X}{\varepsilon_d} + \frac{X}{\varepsilon_p}} \quad (4)$$

Where  $\varepsilon_p$ ,  $\varepsilon_{sp}$  and  $\varepsilon_d$  are the relative permittivity of paper, spacer, and oil respectively.

The test specimens for dielectric testing were made up by placing two paper-wrapped insulated rectangular copper conductor samples each of length approximately 21 cm, side by side in a Perspex assembly so that they overlap each other for a length of 100 mm. The conductors were insulated by 4-5 layers of 75  $\mu\text{m}$  thick standard Kraft insulation paper (cellulose origin, and not thermally upgraded). These paper insulated conductor samples were obtained from a local transformer manufacturing company. The samples ends were boat shaped to conform to the Rogowski profile [14]. 1.5 cm paper insulation was removed from one side of each sample to enable electrical connection. The structure of the paper-wrapped conductor sample and also the test assembly with two samples within the Perspex block is shown in Figure 4. The whole block is placed inside an air tight glass chamber filled with Shell Diala B transformer oil. Testing was not performed until the oil/paper system attained equilibrium. The two paper wrapped conductors act as the two electrodes with the two terminals being connected to the two conductor samples (points A and B as shown in the Figure 4). The distance between the exposed ends of the two electrode ends (point A and B) in the oil filled test chamber is thus more than 20 cm. Such a system will ensure minimum leakage current through the oil between the two electrodes. It was expected that the polarization and depolarization current will entirely pass through the oil impregnated paper insulation between the two electrodes, with minimum leakage through the oil. Such a test system, used in our previous studies [1, 4, 6, 11, 14, 25-27, 29] was able to demonstrate the general trend of oil-paper insulation system's performance to dielectric tests.

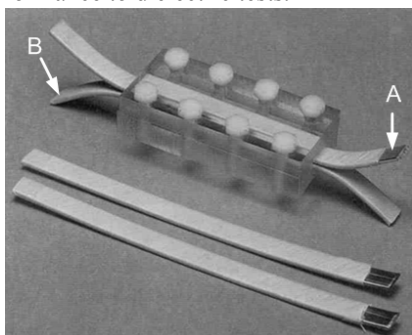

**Figure 4.** Structure of the paper wrapped conductor samples and the test assembly with Perspex blocks used for the study, A and B showing the two terminal ends.

However, such a test sample, with a small capacitance between the two electrodes was suspected to have some leakage current between the electrodes through the surrounding oil, Perspex assembly, and stray capacitances. If the insulation is not grounded on one side (e.g. for measurements between HV and LV winding), PDC measurements can be made in a three electrode arrangement in order to exclude leakage currents and

in order to select insulation parts of special interest. For instance, if the diagnostic voltage can be applied to a HV winding, the diagnostic currents can be taken from the LV winding and all other parts of the transformer (yoke, tank, other windings and conductors) can be used as grounded guard. IEC 60093 [30] recommends the use of guard arrangements in such a case to ensure that all the current passes through the insulation under study and the leakage currents are bypassed. To further investigate this and to ensure the assumption that the experimental setup due to its construction inherently can remove such leakage currents and does not corrupt the actual measurements, a second set of experiments were performed with a temporary guard arrangement. Conducting aluminium foils were wrapped over the Perspex assembly and uninsulated uncovered flexible wire strips closely wound on top of the second sample (the neutral electrode), then to the Perspex assembly were used to provide the guard arrangement. A schematic diagram of the temporary guard arrangement covering the electrodes is shown in Figure 5. One end of the guard was then connected to the neutral electrode of the test arrangement as per [30], by which the leakage current bypasses the ammeter. To investigate the effectiveness of the 'guard' arrangement in the sample setup used for the current study, a series of experiments were performed with and without the guard on samples with different oil and paper conditions. In all cases, it was observed that due to inherent arrangement of the sample structure, as discussed above, no appreciable deviations were found between the currents measured with or without the guard. One such example plot is shown in Figure 6. This 'guard' arrangement is however, not possible for a RVM measurement, which is a two electrode measurement against ground without any guard. For RVM, the guard was removed and measurements were done between LV and HV terminals only.

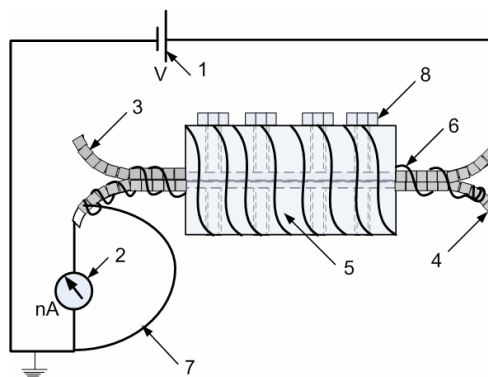

**Figure 5.** Structure of the test assembly with guard arrangement; 1 – High voltage dc source, 2 – Sensitive current measuring device, 3 – Live electrode (paper wrapped conductor sample 1), 4 – neutral electrode (paper wrapped conductor sample 2), 5 – Perspex block with aluminium foil wrapping, 6 – Bare flexible wire strip, 7 – Guard connected to ground, 8 – Perspex Insulated bolts.

It can be observed from Figure 6 that there is only a small variation in current for arrangements with and without guard. As predicted by [30], currents without a guard arrangement will include leakage currents in the measurements. In this case, this difference is, however, very small.

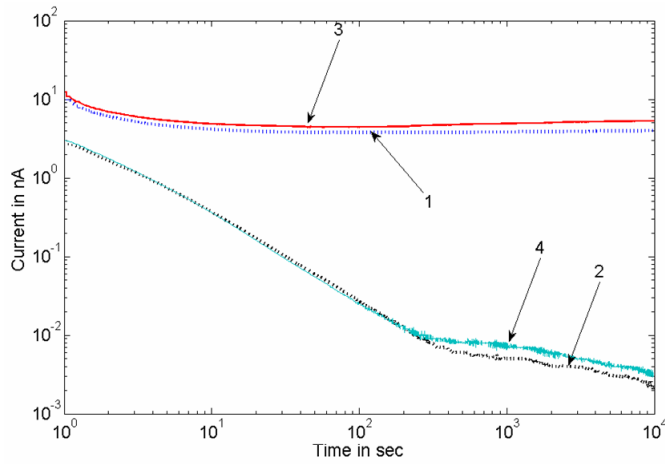

**Figure 6.** Comparison of polarization and depolarization currents obtained from the same test sample tested with and without guard arrangement; 1 – polarization current with guard, 2 – depolarization current with guard, 3 – polarization current without guard, 4 – depolarization current without guard

As discussed earlier, this apparent immunity towards leakage currents is due to inherent structure of the test arrangements used for experiments in this study. To avoid complications and to save time while preparing the test samples for each batch of ageing experiments and SEC measurements, the guard system has not been used for the measurement data shown in the remaining sections of this paper. The loss of accuracy due to omission of the guard, though minimal, can be justified by the fact that the test results are primarily affected by the ageing and moisture effects, rather than the guard, as indicated by Figure 6 and further explained in next sections of this paper.

Use of such a test sample arrangement, once again simplifies the general block diagram of Figure 3 and permittivity values calculated using equation (4). In the present case, the insulation geometry does not include any spacer, such that  $Y=0$ , and the oil gap in between the two sample conductors is minimal, since no spacer is placed inside. In (4), thus,  $X$  is very nearly equal to one ( $X$  nearly = 1). However, there are always oil wedges at the sides along the conductors. Currents passing through these oil wedges should not be included in the measurement. To avoid these currents, the guard wires (Figure 5) were extended to the parts of the sample where oil wedges were present. This ensured that influences due to the presence of oil wedges can be avoided in the measurement. Such a system, though may not be able to entirely represent the complex insulation structure within a transformer, is capable of demonstrating the performance of oil-paper insulation system under different ageing and moisture conditions.

The effective permittivity from equation (4) can then be simplified as:

$$\varepsilon_r = \frac{\varepsilon_p \cdot \varepsilon_d}{\varepsilon_p \cdot (1 - X) + \varepsilon_d \cdot X} \quad (4a)$$

Similarly, the effective conductivity [29] of the insulation system may be written as:

$$\sigma_r = \frac{\sigma_{paper} \cdot \sigma_{oil}}{\sigma_{paper} \cdot (1 - X) + \sigma_{oil} \cdot X} \quad (5)$$

where,  $\sigma_{paper}$  and  $\sigma_{oil}$  are paper and oil conductivities respectively.

The initial polarization current (after the first transient that is normally not recorded) can be written as:

$$i_{pol}(+0) = C_0 U_0 \frac{\sigma_{oil}}{\varepsilon_0} \cdot \frac{\varepsilon_r}{\varepsilon_d} \quad (6)$$

Once the values of the effective permittivity  $\varepsilon_r$  and hence,  $C_0$  is estimated, the oil conductivity can now be calculated as:

$$\sigma_{oil} = \frac{\varepsilon_0 \cdot \varepsilon_d}{\varepsilon_r \cdot C_0 \cdot U_0} i_{pol}(+0) \quad (7)$$

On the other hand, the long-time polarization current (steady dc value  $i_{dc}$ ) can be related to the paper conductivity as:

$$i_{dc} = C_0 \cdot U_0 \frac{\sigma_r}{\varepsilon_0} \quad (8)$$

If  $\sigma_{oil} \gg \sigma_{paper}$ , then from (5) we get

$$\sigma_r = \frac{\sigma_{paper}}{X} \quad (9)$$

Combining equations (8) and (9) we get,

$$i_{dc} = C_0 \cdot U_0 \cdot \frac{\sigma_{paper}}{\varepsilon_0 \cdot X}$$

or,

$$\sigma_{paper} = \frac{\varepsilon_0 \cdot X}{C_0 \cdot U_0} i_{dc} \quad (10)$$

Equations (7) and (10) can thus be used to calculate the oil and paper conductivity values from the measured polarisation current.

### 3 CHEMICAL TEST – MOLECULAR WEIGHT (MW) MEASUREMENT BY SIZE EXCLUSION CHROMATOGRAPHY

Insulation paper is a blend of three main components – cellulose polymer of high molecular weight, hemi-cellulose co-polymers of lower molecular weight and lignin that are aromatic based polymers. As a transformer ages, the chemical and physical properties of the cellulose insulation paper will change. Bond scission of the cellulose main chains results in a decrease in the average molecular weight of the chains and if end effects are ignored, an increase of one chain per scission in the number of chains present. Thus, an investigation of the time dependence of the molecular weight of the cellulose provides information about the rate of main chain bond scission [1, 15-16, 19-20]. Previous studies of the kinetics of insulation paper degradation have been based upon

measurements of the limiting viscosity number of solutions of a cellulose derivative, often the copper-amine complex. Thus, these measurements yield a viscosity average molecular weight,  $M_v$ , for the aged cellulose. Traditionally DP is calculated from the viscosity average molecular weight,  $M_v$ . Although to obtain the rate of bond scission, the number average molecular weight,  $M_n$ , is required.  $M_v$  is always greater than  $M_n$ , and for cellulose, it is close to the weight average molecular weight,  $M_w$ . The authors are in the opinion that DP calculated from the viscosity average molecular weight,  $M_v$ , always shows higher than the original paper strength. The number and weight average molecular weights, however, represent more closely to the rate of bond scission than by the DP measured by the viscosity average molecular weight,  $M_v$ . The number average and weight average molecular weights are defined as:

Number average molecular weight

$$M_n = \frac{\sum(n_i \cdot M_i)}{\sum n_i} \quad (11)$$

and, Weight average molecular weight

$$M_w = \frac{\sum(n_i \cdot M_i^2)}{\sum(n_i \cdot M_i)} \quad (12)$$

where,  $n_i$  is the number of chains of mass  $M_i$ .

However,  $M_v$  is also dependent on a number of factors, including the choice of solvent and the nature of the molecular weight distribution of the sample [1]. Because paper insulation is a blend of cellulose, hemi-cellulose and lignin, it is not scientifically appropriate to attempt to characterise the effects of degradation using single measures such as number or weight average molecular weights ( $M_n$  or  $M_w$ ) and the related number or weight averaged degree of polymerization  $DP_n$  or  $DP_w$  [11]. The same criticism holds for the DP determined using the viscosity method ( $DP_v$ ), perhaps more harshly in this case, because the viscosity method and the procedures used to derive  $DP_v$  are suspect with multi-component polymers [17-18]. In [17-18] it was pointed out that the initial mono-modal distribution changes to a multi-modal distribution during ageing, but eventually returns to mono-modal as the DP of the cotton reaches a limiting value of 150–200. Such complex changes in the molecular weight distribution cannot be reflected truly in any average value such as the DP, rather it is required to have the multi-modal distribution, a pattern as obtained through SEC.

Even so,  $DP_v$  has been widely used by many researchers to monitor the degradation of cellulosic chains in ageing paper and to correlate it with other changing properties such as tensile strength and furans production.

The viscosity method does not provide any direct information about the molecular weight distribution of the cellulose chains, which is now known to be important in the determination of many polymer properties. Molecular weight determination based upon Size Exclusion Chromatography (SEC) yields

information about the complete molecular weight distribution of the cellulose chains present in the insulation materials in a transformer. It therefore provides a more detailed picture of the ageing process for the cellulosic components of insulation material [31]. Figure 7 [1] shows the SEC chromatograms of a new and a used cellulose insulation papers. The chromatogram of the new cellulose insulation paper shows the presence of two components. One component at lower retention time (high molecular weights) is due to cellulose, while the smaller, lower molecular weight component, is due to hemicellulose. In the chromatogram of the cellulose insulation paper taken from an aged transformer, the molecular weight of the cellulose component has decreased significantly. The molecular weight distribution of the cellulose has also broadened considerably, and the peak due to the hemicellulose has become barely detectable, suggesting that the hemicellulose component of the paper may have been largely degraded. Very often peaks of the molecular weight distribution of cellulose paper (as identified in the Figure 7) are also used for identifying the insulation degradation.

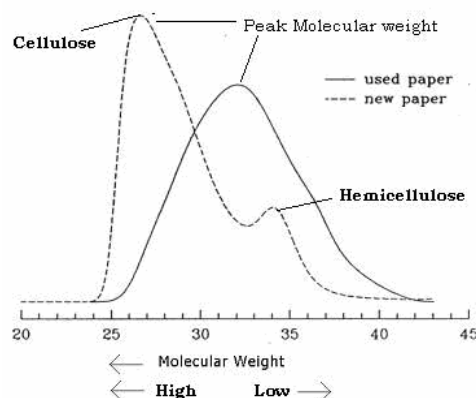

Figure 7. SEC chromatograms of new and old paper samples

In our previous work, we have suggested that sometime three peaks are easily traceable from a molecular weight distribution of a cellulose paper. Peak-1, peak-2 and peak-3 have been related to cellulose, decomposed cellulose and hemicellulose respectively. We also have correlated these peaks to number of polymer chains and to Degree of Polymerisation ( $DP_v$ ) as measured by viscosity average molecular weight,  $M_v$  [11]. Since peak-1 also changes significantly with ageing of paper, we are presenting peak-1 molecular weight ( $M_p$ ) along with  $M_w$  and  $M_n$  from the SEC measurements.

### 3.1 SEC MEASUREMENT PROCEDURE

For SEC analysis, the paper is first cleaned by washing with Soxhlet extractor in Di-Chloro Methane (DCM) for about 63 h. Then the samples were washed with fresh DCM in large bottle under vibration for 6 h. The samples were then rinsed with fresh DCM before high vacuum drying at 35 °C for 12 h.

Cellulose is not readily soluble in simple organic solvents. For this reason the cellulosic components need to be modified to improve their solubility. There is a concern among users of the SEC technique for cellulose, that the method of dissolution of the cellulose can cause further degradation of the material [32]. Previous works at the University of Queensland [1]

demonstrated that the certain modifications in the process using phenyl isocyanate derivatives, as shown by Evans *et al* [33] offer several advantages. In particular they have shown that, through the use of mild reaction conditions in pyridine solvent, degradation of the cellulose chains during derivatization can be avoided. In this project, the procedure of Evans *et al.* [33] has been modified for use in preparing the tricarbonyl derivatives of the cellulose polymers in Kraft paper. Samples were cut into small pieces and weighed (5-10 mg) and placed in a vial. Aliquots of 1.2 mL phenylisocyanate and 12 mL pyridine were added to each vial. The pyridine was freshly purified to remove the moisture (by adding sodium hydrogen carbonate overnight and then freshly distilled under lower vacuum at 72-76 °C). The reaction stock was shaken/swirled at 100 rpm, 80 °C for 41 h. Then 1 mL of methanol was added to stop the reaction. The resulting clear, viscous solution was cooled and the cellulose tricarbonyl precipitated by adding the solution to 100 mL of stirred methanol. The cellulose tricarbonyl precipitate was further purified by dissolution in acetone followed by precipitation in water: methanol mixture (70:30). It was then dried in a vacuum oven at 50 °C for 12 h.

The molecular weight of cellulose tricarbonyl was measured using a Waters Chromatograph with a variable wavelength tunable absorbance detector [31]. Four ultra-styragel columns were used in series in the chromatograph with tetrahydrofuran (THF) as the eluent. The cellulose tricarbonyl samples were dissolved in THF at a concentration of 0.1% w/v, filtered (0.45 µm), injected via a 200 µL loop and eluted at a flow rate of 1.0 mL/min. Detection was carried out using the absorbance at 236 nm and the elution profiles were acquired through interfacing to a computer. The elution profiles were converted to molecular weight distributions using a calibration based upon narrow molecular weight distribution polystyrene standards.

#### 4 MOISTURE CONDITIONING AND ACCELERATED AGEING EXPERIMENT

A method was developed [27] to control the moisture level of insulation paper using the Piper chart [34]. A set value of paper moisture level was achieved by controlling the pressure of water vapour and temperature inside a closed container for a long period. The starting moisture contents of both the oil and paper samples were measured using Karl Fischer Titration method using a 737 KF Coulometer from Metrohm. According to ASTM D 3277-73 [35], a methanol/chloroform mixture was used to extract water from the paper samples for measurement. Details of the moisture conditioning procedure have been discussed in [27]. Dry and degassed transformer oil (Shell Diala B) was then added to the container so that the conductors were completely immersed in the oil. Figure 8 shows the moisture-conditioning set-up developed at the University of Queensland.

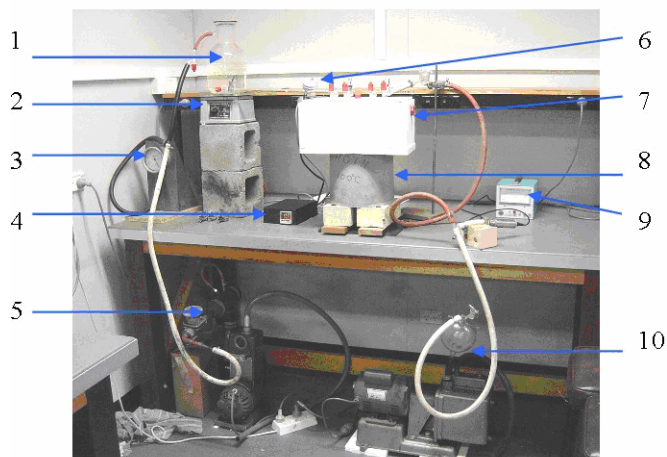

**Figure 8.** Paper moisture conditioning set-up; 1 - Oil container, 2 - Heater and stirrer for oil, 3 - Pressure gauge for oil, 4 - Temperature controller for the conditioning vessel, 5 - Vacuum pump for oil, 6 - Thermocouple probe for conditioning vessel temperature control, 7 - Conditioning vessel with heat reserving jacket, 8 - Heating block for conditioning vessel, 9 - Pressure gauge for conditioning vessel, 10 - Vacuum pump for conditioning vessel.

Adequate time was provided for the oil-paper system to attain equilibrium before the samples were transferred to separate ampoules for entering the artificial accelerated ageing process. Two different sets of moisture levels were preset for the paper samples. A group of paper samples were set to 2% moisture and the other group to 5% moisture. The accelerated ageing experiments were performed at 95 °C in aluminium block heaters for various periods of 120 days, 240 days and 360 days.

The ageing ampoules contained the moisture-conditioned paper wrapped conductor, oil and air in the remaining space. The ageing ampoules were sealed with vacuum grease so that there was no contact with the ambient.

During the ageing process, the degradation of paper produces moisture. Therefore, it was expected that after the ageing period was over, the moisture content of the paper would increase from its initial preset value. In reality, however, the moisture contents of the three different mediums inside the ampoules – paper, oil and air always tend towards an equilibrium position with respect to moisture [34]. Moisture thus tends to flow out from higher concentrations towards lower concentrations. The initial condition of the oil and the air inside the ampoules being relatively drier than the moisture conditioned paper, there is always a migration of moisture from paper to the oil and then to the air. The situation is schematically described by Figure 9. Figure 9 shows the schematic diagram of the glass ampoule used for artificial ageing of oil and paper at high temperature. The ampoules were approximately 45 mm in diameter and 54 cm tall. In each glass ampoule 8 paper wrapped conductor samples each of length 21 cm were immersed in about 230 mL of oil. Thus the paper to oil ratio was approximately 86 mg/mL. This is similar to that found in many transformers.

At the ageing temperature of 95 °C, the vapour pressure of water is 633 mm of Mercury, which is quite close to ambient pressure. In an attempt to attain equilibrium, there will be a redistribution of moisture between paper, oil and air inside the ampoules.

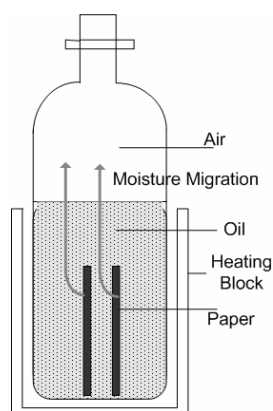

**Figure 9.** Schematic diagram of moisture migration from paper to oil to air inside the ageing ampoule

Thus, it is expected that some moisture will turn into water vapour and migrate from the paper towards the air through the oil till equilibrium is achieved. This migration of moisture is further enhanced by the higher affinity of the oil towards absorbing moisture from paper as the degradation of oil produces acidic compounds. This migration process, though very slow, will affect the distribution of moisture between paper, oil and the air inside the ageing ampoules. With a longer time, more moisture will migrate out of the paper towards the oil and then to the air. This migration will also be affected by the relative concentration gradient of moisture between paper, oil and air. Since in the 5% moisture sample, the moisture concentration inside paper is more as compared to the 2% moisture sample, the amount of moisture migrating out of the paper while ageing, is expected to be more in case of the 5% moisture sample than the 2% moisture sample. This hypothesis has been illustrated by a combined figure (Figure 18) at the end of the results section. Thus, the effect of this ‘moisture migration’ may override the effect of moisture produced in the paper due to ageing and the actual moisture content values in the paper may be found to decrease after the pre-set ageing periods. The higher the periods of ageing, the higher will be the amount of moisture migrating out of the paper. It is to be noted that, along with moisture, there will be other volatile products of ageing, which being in traces are difficult to measure or estimate, and thus are out of the scope of this present study. A more comprehensive study in future can be useful for complete record of all the volatile ageing products.

After ageing, the samples were allowed to cool down to room temperature and removed from the oil. Paper samples were then removed from the conductor for moisture measurement and SEC analysis and the insulated conductors were used for dielectric tests. The summary of the different test samples with their corresponding ageing and moisture content status after ageing is presented in Table 1.

The oil and paper moisture contents have been measured by Karl Fischer Titration technique at ambient temperature by methanol/chloroform extraction method [35] using the Karl Fischer Titration Coulometer. Two samples of paper were collected for moisture measurement. The first one was 250 mg and the second one was 500 mg. The test samples were then

transferred to the testing ampoules for dielectric tests (RV and PDC). Both RV and PDC measurements were performed under ambient temperature conditions in a sealed oil filled tank. The results of RV, PDC and the chemical test (SEC) are presented in the next section.

**Table 1.** Summary of the test samples

Name	Sample	Final moisture contents after ageing	
		Oil (ppm)	Paper (%)
R	Dry reference sample	9	1.0
A	2% Unaged sample	10	1.8
A1	2% 120 Days aged sample	14	2.5
A2	2% 240 Days aged sample	19	2.5
A3	2% 360 Days aged sample	20	2.0
B	5% Unaged sample	18	5.2
B1	5% 120 Days aged sample	22	5.0
B2	5% 240 Days aged sample	17	4.5
B3	5% 360 Days aged sample	16	4.0

## 5 EXPERIMENTAL RESULTS AND ANALYSIS

### 5.1 DIELECTRIC TEST RESULTS

#### 5.1.1 2% MOISTURE CONTENT PAPER SAMPLES A, A1, A2 AND A3

The plot of the RV spectra for the samples A, A1, A2 and A3 is shown in Figure 10. The RV spectra corresponding to the dry reference sample R is also included in Figure 10 for comparison. The values of the peak of the RV spectra and the central time constant (CTC) values are summarised in Table 2.

The dry reference sample R with the lowest value of oil and paper moistures among all the samples, has the highest value of central time constant (CTC) followed by the unaged sample A. As observed from Table 1, the paper and oil moisture contents of samples A1, A2 and A3 are quite close. It has been observed that for samples with a large difference in their moisture contents, the central time constant values can vary in the order of tens. It is believed that the central time constant of the RV spectra is more dependent on the moisture content of the oil-paper composite insulation than the ageing [1]. This explains the fact that the CTC values of the three aged samples A1, A2 and A3 are very close to each other. It is very difficult to understand clearly the individual effects of oil and paper condition from the RVM curves. It is believed that RVM is a complex convolution of the individual effects of oil and paper and their moisture and ageing conditions.

It has been reported by several researchers [6-10, 28-29] that the PDC measurement technique has the potential of identifying the individual effects of oil and paper separately. It was reported that the condition of the oil mainly affects the initial parts of the polarization and depolarization currents, whereas the final long-time values of these currents are related to the paper condition [5-10, 28-29].

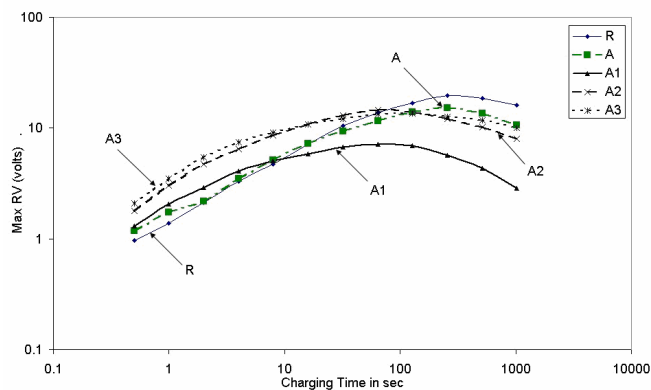

**Figure 10.** RV spectra plot for samples A (2% unaged), A1 (2% 120 days aged), A2 (2% 240 days aged) and A3 (2% 360 days aged) and the dry reference sample R.

**Table 2.** RV measurement summary for samples R, A (2% unaged), A1 (2% 120 days aged), A2 (2% 240 days aged) and A3 (2% 360 days aged).

Sample	Peak of RV spectra (volts)	Central time constant (s)
R	21	910
A	16	260
A1	6	105
A2	15	110
A3	14	120

A series of systematic investigations of water content on paper conductivity which were performed on plane material samples between guard ring electrodes were reported in [36]. It was demonstrated that increasing temperature cause exponentially increasing polarization currents. They used a ‘charge Difference method (CDM)’ to calculate the dc conductivities. Increasing water contents resulted in increasing conductivities for all temperatures. Conductivities at elevated temperatures were used to calculate room temperature values by Arrhenius’ law, involving activation energy and temperature. They obtained good agreement with directly measured values over the whole range of technically relevant moisture contents. It was reported that if the temperature is known, PDC measurements can be normalized to a reference temperature and comparisons can be done more meaningfully.

The polarization and depolarization currents for samples A, A1, A2 and A3 are plotted in Figures 11 and 12, respectively along with the corresponding currents for the dry reference sample R for comparison. The oil and paper conductivity values calculated using equations (7) and (10) respectively are presented in Table 3. The oil and paper moisture values are also included in Table 3 for highlighting the correlation between the moisture and the conductivity values.

It is evident from Figure 11 that the polarization current for the dry reference sample R is much different from the other four. Lower values of polarization current normally denote a good condition of insulation. The initial current magnitudes of samples R and A are quite close which is indicative of the fact their oil conditions are quite similar. The initial polarization current magnitude of A1 is lower than those for A2 and A3, which agrees well with the fact that the moisture in oil for A1 (14 ppm) is lower than A2 and A3 (19 and 20 ppm

respectively). The fact that A2 and A3 have very close values of oil moisture content is depicted by their almost overlapping values of polarization current during the initial period. The long-term value of the polarization current for the dry reference sample R lies well below all the other samples. Sample A with the lowest paper moisture content among the four samples has its final polarization current value below those corresponding to A1, A2 and A3. Long-term polarization current values for A1 and A2 are close to each other but both are higher than A3, which once again is in agreement with the fact that the paper moisture contents of A1 and A2 are close to each other and are more than that for A3.

Similar nature of variation of the depolarization currents were found for samples A, A1, A2 and A3 as shown in Figure 12. The depolarization currents for the dry reference sample R, closely followed by that for the unaged sample A, are lying below the other three. The initial portion of the depolarization current for A1 lies below A2 and A3 indicating that its oil condition is better the other two samples A2 and A3. The long-term values of the depolarization currents of A2 and A3 are found to be very close to each other.

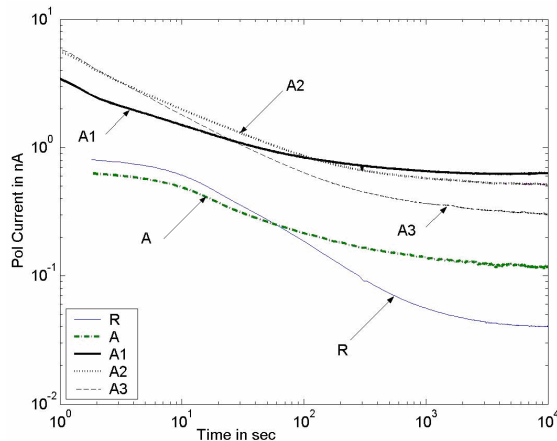
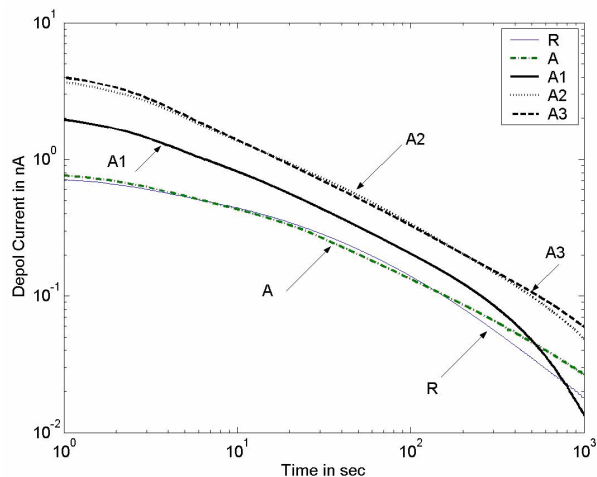

**Figure 11.** Polarisation currents for samples A (2% unaged), A1 (2% 120 days aged), A2 (2% 240 days aged) and A3 (2% 360 days aged) and the dry reference sample R.

The conductivity values presented in Table 3 show a good agreement with the corresponding oil and paper moisture contents. The dry reference sample R, as expected, is found to have the lowest values of oil and paper conductivities among all the samples. The conductivity values of oil and paper for the other four samples A, A1, A2 and A3 are in accordance to their oil and paper moisture content values respectively. The lower the moisture contents, the lower are the values of corresponding conductivities.

As seen in Table 3, the oil conductivity values of A1, A2 and A3 are much higher than the oil conductivity of the unaged sample A, and the dry reference sample R. The oil conductivities of A2 and A3 are higher than that of sample A1. This has good correlation with the fact that A2 and A3 have the highest (similar) oil moisture content among the three aged samples. On the other hand, the paper conductivity values of both A1 and A2 are higher than that of A3, which agrees with the fact that the paper moisture contents of A1 and A2 are

higher than that of A3. The samples R and A, having lower values of paper moisture contents, have much lower values of paper conductivities compared to the rest.



**Figure 12.** Depolarization currents for samples A (2% unaged), A1 (2% 120 days aged), A2 (2% 240 days aged) and A3 (2% 360 days aged) and the dry reference sample R.

**Table 3.** Moisture and conductivity values of samples R, A (2% unaged), A1 (2% 120 days aged), A2 (2% 240 days aged) and A3 (2% 360 days aged).

Sample	Moisture content		Conductivity (pS/m)	
	Oil (ppm)	Paper (%)	Oil	Paper
R	9	1.0	0.53	0.056
A	10	1.8	0.57	0.16
A1	14	2.5	2.6	0.53
A2	19	2.5	4.2	0.56
A3	20	2.0	4.4	0.40

### 5.1.2 5% MOISTURE CONTENT PAPER SAMPLES B, B1, B2 AND B3

The plot of the RV spectra for samples B, B1, B2 and B3 is shown in Figure 13. The RV spectra corresponding to the dry reference sample R is also included in Figure 13 for comparison. The values of the peak of the RV spectra and the central time constant (CTC) values are summarised in Table 4.

The dry reference sample R, with the lowest value of oil and paper moistures among all the samples, has the highest value of central time constant. The other four samples B, B1, B2 and B3 have values of CTC too close to differentiate from each other. Though small variations of oil and paper moisture content between B, B1, B2 and B3 are observed in Table 1, the RVM is not expected to be sensitive to such small variations of moisture contents.

**Table 4.** RV measurement summary for samples R, B (5% unaged), B1 (5% 120 days aged), B2 (5% 240 days aged), B3 (5% 360 days aged).

Sample	Peak of RV spectra (volts)	Central time constant (s)
R	21	910
B	8	160
B1	20	186
B2	10	185
B3	17	200

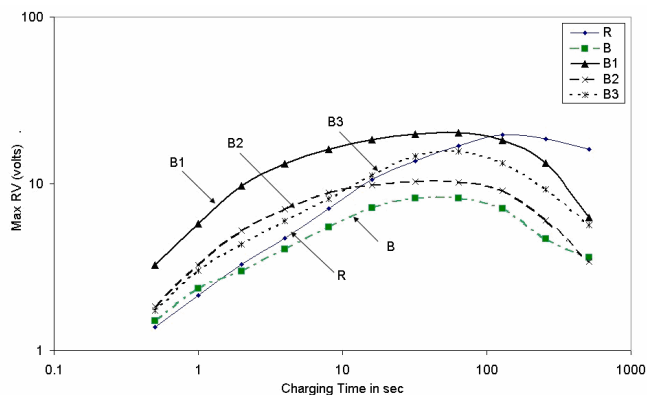

**Figure 13.** RV spectra plot for samples B (5% Unaged), B1 (5% 120 Days Aged), B2 (5% 240 Days Aged), B3 (5% 360 Days Aged) and the dry reference sample R.

The PDC technique, on the other hand promises to solve this problem by separately identifying the effects of oil and paper condition. Figures 14 and 15 show the nature of polarization and depolarization currents respectively for samples B, B1, B2 and B3. The plots for the dry reference sample R are also included for comparison.

As shown in Figure 14 and Figure 15, the initial portions of polarization and depolarization currents for sample B1 having the highest oil moisture content, lies on the top followed by B, B2, B3 and the dry reference sample R respectively. The dry reference sample R, having lowest paper moisture content has final parts of its polarization current lying well below the other four samples during longer time. The final parts of the polarization currents for B and B1 are quite close, which is indicative of the fact that their paper moisture content values are close (Table 1). Similarly, the final values of the polarization currents for samples B2 and B3 are also quite close. Due to some unidentified errors in the measurement, the depolarization current for B3 has been polluted with some noise and its magnitude seems to be too low.

**Table 5.** Moisture and conductivity values of samples R, B (5% unaged), B1 (5% 120 days aged), B2 (5% 240 days aged), B3 (5% 360 days aged).

Sample	Moisture content		Conductivity (pS/m)	
	Oil (ppm)	Paper (%)	Oil	Paper
R	9	1.0	0.53	0.056
B	18	5.2	3.9	1.2
B1	22	5.0	6.0	1.1
B2	17	4.5	3.5	0.88
B3	16	4.0	2.5	0.78

The conductivity values for both oil and paper have been estimated from the polarization currents and are presented in Table 5. As anticipated, the oil and paper conductivity values for the dry reference sample R is much lower than the other samples. Sample B, with the highest value of paper moisture content has the highest value of paper conductivity as well, closely followed by sample B1. The conductivity values for B2 and B3 are, however, very close to each other since their oil and paper moisture content values are not too different.

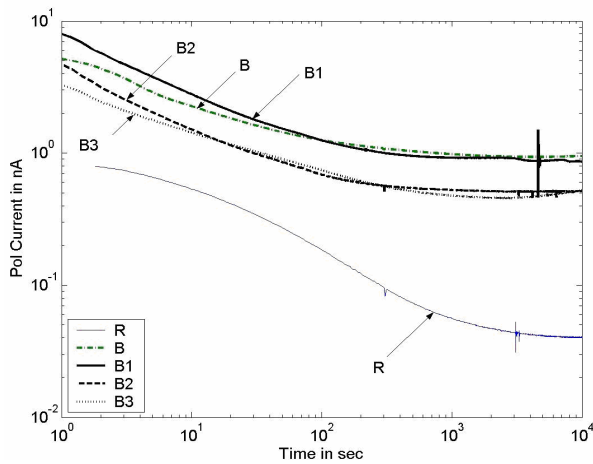

**Figure 14.** Polarization currents for samples B (5% unaged), B1 (5% 120 days aged), B2 (5% 240 days aged), B3 (5% 360 days aged) and the dry reference sample R.

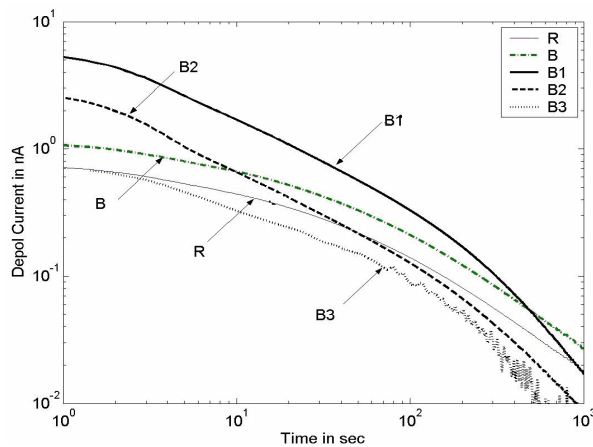

**Figure 15.** Depolarization currents for samples B (5% unaged), B1 (5% 120 days aged), B2 (5% 240 days aged), B3 (5% 360 days aged) and the dry reference sample R.

As seen in Table 5, the paper and oil conductivity values have a certain proportional trend of variation in relation to the moisture contents. However, at the end one should acknowledge the fact that such small variation in moisture contents are very difficult to differentiate as these values are always subjected to measurement inaccuracies.

A related work has been published in [36], where aged bushings with aged oil impregnated paper were investigated. It is reported that severely aged bushings could be detected from significantly enhanced polarization currents within the first seconds. Therefore it seems that PDC analysis provides an indication of ageing from the initial current values. Long term polarization currents are influenced both by water content and by ageing.

Ageing at 95 °C produces water and other ageing by-products, which are polar in nature. Polarization measurements are bound to be affected by both ageing and moisture. In reality, however, we observe that variation in moisture content has more significant effect than the ageing by-products. In summary, it can also be concluded that ageing at 95 °C is not enough to substantially influence the RV measurements even for an ageing up to 360 days. The amount of moisture that may

be produced due to ageing will be eclipsed by the moisture migration out of the paper towards oil and air. As a result, the RVM, which is believed to be a combined effect of oil and paper moisture/ageing, is found to be rather insensitive in identifying accurately the moisture/ageing status of the different samples. It is however, pertinent to mention here that RVM analysis completely neglects geometric influences. Therefore RVM results are only relevant for homogeneous materials and can not be understood clearly for oil-barrier systems. PDC test on the other hand, provides encouraging results showing the effects of oil and paper moisture contents separately.

## 5.2 CHEMICAL TEST (SEC) RESULTS

After the electrical tests were completed, molecular weight measurements were performed on the paper samples by the Size Exclusion Chromatography (SEC). Results from these measurements are presented here.

The SEC chromatogram for the samples R, A, A1, A2 and A3 are shown in Figure 16. The normalized peak molecular weight is found to decrease with increased ageing and the peaks shift towards higher retention times (lower molecular weight) as the ageing increases. The Number Average Molecular Weight ( $M_n$ ), the Weight Average Molecular Weight ( $M_w$ ), and the Peak Molecular Weight ( $M_p$ ) for the above samples are summarized in Table 6. The peak molecular weight ( $M_p$ ) is obtained as the peak value of the SEC chromatogram before normalization.

**Table 6.** Molecular weight distribution of paper samples A (2% unaged), A1 (2% 120 days aged), A2 (2% 240 days aged) and A3 (2% 360 days aged) and R.

Sample	$M_n (\times 10^5)$ g/mol	$M_w (\times 10^5)$ g/mol	$M_p (\times 10^5)$ g/mol
R	2.45	7.42	11.1
A	2.30	7.31	10.8
A1	1.63	6.57	9.67
A2	1.40	6.23	8.75
A3	1.12	5.91	5.88

When the aging time was longer, the molecular weight was found to decrease. Since the molecular weight can be related to the number of chains present in the cellulose paper, a lower value of molecular weight implies more scission of the chains. Thus, low molecular weight means more degradation of the samples. Thus the paper samples are found to degrade more with ageing.

The SEC chromatogram for samples R, B, B1, B2 and B3 are shown in Figure 17. As expected, the peaks of the SEC chromatograms corresponding to the aged samples B1, B2 and B3 are lower than the dry reference sample R, and the unaged sample B. In addition, the peaks corresponding to the aged samples are found to shift towards higher retention time (lower molecular weight) as compared to the reference sample. The values of  $M_n$ ,  $M_w$ , and  $M_p$  for samples B1, B2 and B3 are presented in Table 7. The aged samples B1, B2 and B3 have lower values of  $M_n$ ,  $M_w$  and  $M_p$  as compared to the unaged reference sample R and the unaged sample B. Sample B1 with 120 days ageing has higher values of  $M_n$ ,  $M_w$  and  $M_p$  than the

corresponding 240 days and 360 days aged samples B2 and B3. It is seen from Figure 17 and also from Table 7, that there is no significant difference between samples B2 and B3.

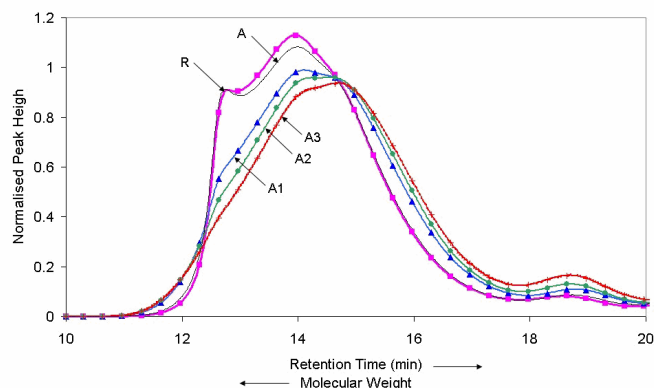

**Figure 16.** SEC chromatograms for samples A (2% unaged), A1 (2% 120 days aged), A2 (2% 240 days aged) and A3 (2% 360 days aged) and the dry reference sample R.

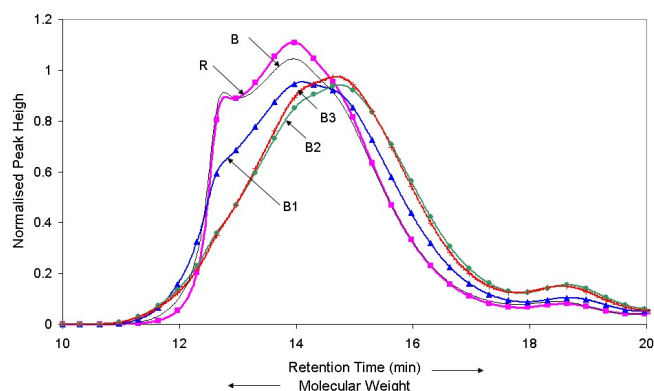

**Figure 17.** SEC chromatograms for samples B (5% unaged), B1 (5% 120 days aged), B2 (5% 240 days aged), B3 (5% 360 days aged) and the dry reference sample R.

It was expected that samples B, B1, B2 and B3 with 5% paper moisture contents would show a higher degree of ageing over the 2% moisture-content samples A1, A2 and A3 respectively. From Tables 6 and 7, the  $M_n$ ,  $M_w$  and  $M_p$  values of the unaged sample B with 5% paper moisture content is found to be slightly lower than those for the unaged sample A with 2% paper moisture content.

**Table 7.** Molecular weight distribution of paper samples B (5% unaged), B1 (5% 120 days aged), B2 (5% 240 days aged), B3 (5% 360 days aged) and R.

Sample	$M_n (\times 10^5)$ g/mol	$M_w (\times 10^5)$ g/mol	$M_p (\times 10^5)$ g/mol
R	2.45	7.42	11.1
B	1.82	7.16	10.1
B1	1.78	6.62	9.78
B2	1.15	5.78	5.64
B3	1.33	5.95	5.86

However, no significant variation of the values of  $M_n$ ,  $M_w$  and  $M_p$  are observed between samples A1 and B1, which are aged for the same 120 days at 95 °C but with different moisture contents. Similar situations are observed for the 360 days aged samples A3 and B3. The 240 days aged sample from the 5% moisture content batch (sample B2) is found to have lower

values of  $M_n$ ,  $M_w$  and  $M_p$  as compared to the corresponding 2% paper moisture content batch (sample A2). Thus, ageing at the same initial moisture level is clearly differentiated by SEC, but correlating ageing effects of samples with different initial moisture contents does not seem to be that straightforward. It is thus difficult to establish the inter-relationship between moisture and ageing at such low temperature (95 °C) and ageing periods limited to 120, 240 and 360 days. More controlled experiments are needed to investigate all controlling factors of ageing and moisture production.

### 5.3 COMBINED SUMMARY

The results obtained from RVM, PDC and SEC measurements can now be summarized in Figure 18. The important parameters that are plotted in the figure include the central time constant, oil conductivity, paper conductivity and maximum peak molecular weight. The samples used for comparison are the dry reference sample (R), the 2% moisture and unaged sample (A), the 5% moisture and unaged sample (B), the 2% moisture and 360 days aged sample (A3), and the 5% moisture and 360 days aged sample (B3). All the parameters are plotted in per unit scales so that they can be accommodated in the same graph for a better comparison.

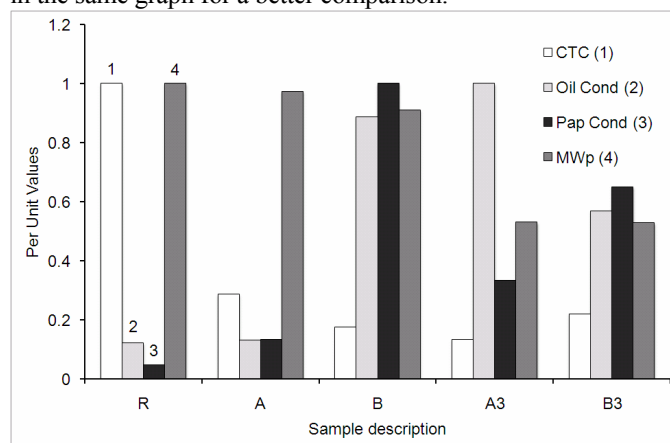

**Figure 18.** Comparative summary of results; R – Dry reference sample, A – 2% unaged, B- 5% unaged, A3 – 2% 360 days aged, B3 – 5% 360 days aged.

It is observed from Figure 18 that the peak molecular weight ( $M_p$ ) values for the samples R, A and B are almost the same. This shows that the molecular weight of the paper insulation does not change just due to the moisture level. After 360 days ageing, the samples A3 and B3 with different initial moisture contents are once again very close to each other. However, their  $M_p$  values are greatly reduced from the corresponding unaged values. One would expect that ageing with high moisture level would reduce the peak molecular weight more significantly than with low moisture for the same period of ageing. Probably the ageing temperature of 95 °C was not high enough to make this variation as distinctive as one would have thought. The second reason could be that the chain scission followed a zero order model, i.e. the rate of bond scission is constant. The third reason of ageing and moisture effect not that distinctly prominent may be due to the absence of free oxygen in the ageing ampoules. It was described in [37] that according to Fabre and Pichon [38],

oxygen increases the rate of degradation of paper in oil containing 0.3-5% moisture by a factor of 2.5 and water increases the rate in simple proportion to its concentration. Reducing the oxygen from saturation level in the oil (30000 ppm) to less than 300 ppm reduces the ageing by a factor of 16. This confirms the observation made at the end of section 5.2, that the molecular weights are more influenced by the ageing effects rather than the moisture contents.

Comparing the oil and paper conductivity values of A and B with respect to each other and also with respect to R in Figure 18, it is apparent that both these conductivity values are strongly influenced by the moisture contents. Sample B (unaged) with 5% moisture content have much higher values of oil and paper conductivity values as compared to sample A with 2% moisture and sample R (dry). Similar observations can be made with the central time constant (CTC) values, with sample B having the least value of CTC among those of samples R, A and B.

After 360 days ageing of the sample A, both the oil and paper conductivity values of A3 are found to be more than those of sample A in Figure 18. The CTC of sample A3 is also found to be lower than sample A. This indicates the fact that ageing has indeed degraded the insulation and has increased the oil and paper moisture contents within the test ampoule.

However, a reverse trend takes place for ageing of the sample B. After 360 days ageing at 95 °C, it is seen in Figure 18 that sample B3 has lower values of oil and paper conductivities and higher value of CTC as compared to those for the sample B. This indicates that there has been a moisture migration out of the paper and oil. This confirms the hypotheses proposed in section 4 that due to concentration gradient of moisture between paper, oil and air on top of oil in the ampoule, there was some re-distribution of moisture till equilibrium was achieved and as a result moisture might have migrated out of the paper and oil. This phenomenon was not severe with the 2% samples A and A3 since in that case, the moisture concentration gradient, obviously was lower between paper, oil and air.

One more reason for this reverse trend may be a rearrangement of the moisture equilibrium as the samples cooled down to room temperature before they were removed from the oil for further testing. In addition, during the whole process there may have been some air ingress. It was pointed out in [37] that in such cases, there may be an opposed interaction between oxygen and water, which may result in a reduction in ageing rate at low water levels and low temperatures when the oxygen concentration in the oil increases due to ingress of air.

Findings in this work agrees with the study reported in [39], that all of the dielectric response methods (RVM, FDS, PDC) reflect the same fundamental polarization and conduction phenomena in transformer insulation, the special feature of which is a combination of oil gaps and solid insulation. Due to the influence of oil gaps, the condition of the oil-specifically its conductivity-has a significant impact on dielectric response. This must be taken into account when attempting to estimate moisture contents in the solid insulation from the results of all

three methods. Regarding the geometry, it has an influence on the response, but not as significant as the effect of the oil conductivity. It was reported that it is primarily the existence of the gaps rather than their detailed dimensions that has the main impact on the results of the measurements.

For the RVM technique, the old interpretation-based only on a simple relationship between the dominant time constant of the polarization spectrum and the water content in cellulose-is not correct. The PDC measurement however, can provide several additional advantages [7-8, 29, 36] such as – information about dc conductivities containing information about moisture, oil-quality and ageing and these time domain signals can be clearly described and explained by physical models (ion movement in oil).

When ageing is related to depolymerization of cellulose molecules, it is important for the mechanical strength of the paper but not for the dielectric properties. It can be detected by chemical analysis (GPC or SEC, DP), but not by dielectric analysis. It should be noted that another understanding of ageing refers to the degradation of oil properties [36] which are very important for dielectric properties (e.g. dissipation factor). Loss of oil quality can be detected from oil conductivity, i.e. by means of equation (7). Experimental results presented on the basis of dielectric response methods (Figures. 11-15 and Tables 3 and 5) fit to this theory put forward in [36].

In summary, it is found that the molecular weight measurement by the SEC technique can provide us with very convincing indication of the ageing of the paper insulation. On the other hand, dielectric testing (especially PDC), as discussed in Section I, can be used to estimate the moisture content of the insulation. Thus, combining the dielectric and the chemical testing it seems possible to estimate the effects of ageing and moisture on the insulation separately. More tests and analysis of results on actual transformers will be useful for validation of these observations regarding separation of the effects of ageing and moisture.

## 6 CONCLUSIONS

An attempt has been made in this paper to study the moisture and ageing impacts in oil-paper insulation by time domain polarization and SEC measurements respectively. Two different moisture conditioned paper samples at 2% and 5% were prepared for this investigation. These paper wrapped conductor samples were then aged with hydrocarbon oil at 95 °C for three distinct periods of 120, 240 and 360 days. RV measurements showed a significant difference between unaged and aged samples, while it failed to isolate samples with different ageing periods. PDC measurement results were found to be in general responsive to different moisture levels produced at different ageing periods. Time-domain polarization measurements (RVM and PDC) were found to be more sensitive to moisture content than ageing of the insulation.

Then molecular weight measurements were performed on these aged and unaged paper samples by the Size Exclusion

Chromatography (SEC) technique. A number of parameters (e.g. number average, weight average and peak average molecular weight) were calculated from these measurements. As the oil-paper samples are aged for longer periods, it is expected that paper chains would be undergoing more scission process. This is normally reflected as a reduction in both the number average and weight average molecular weights. Peak molecular weight is often used as an indicator to measure ageing process. Peak molecular weight also drops as the polymer undergoes more ageing. Trends of ageing were observed for both 2% and 5% moisture content samples. Paper molecular weight dropped consistently with longer periods of ageing.

It is normally believed that polymer chain scission is catalyzed by water content in paper at higher temperature. In the current set of experiments, the ageing temperature was maintained at 95 °C with 2% and 5% paper moisture contents. When comparing 2% and 5% aged samples, no significant difference in molecular weights was observed- suggesting that molecular weights are more sensitive to temperature, and periods of ageing than moisture levels. To prove or disprove this, more controlled ageing experiments need to be conducted.

In general, it is concluded that polarization based diagnostics are more sensitive to moisture and molecular weight measurement is more sensitive to thermal ageing at higher temperature. These two complementary methods, if analyzed carefully, can be very useful to understand moisture and ageing impacts on oil-paper insulation.

SEC method can only be applied when paper samples are extracted from a field transformer. This option is not always available for diagnosis. For this reason many indirect methods are used for the diagnosis of paper ageing. For example, furan analysis is very often considered as a direct indication of paper ageing. Hence molecular weight or DP measurement is only feasible when a transformer is taken out for maintenance. Moisture in transformer insulation can be accurately estimated from the PDC measurement. If a decision is taken for oil reclamation or paper drying then paper/pressboard can be extracted from the easily accessible areas and SEC can be used by a suitable laboratory for investigating the ageing status of transformers insulation.

## 7 ACKNOWLEDGEMENTS

The authors would like to acknowledge the contributions made by Associate Prof. D. J. T. Hill, Dr. Tri Le and Ms. Liying Shao, School of Molecular & Microbial Sciences, University of Queensland, Australia, during molecular weight measurements by SEC technique.

## 8 REFERENCES

- [1] D. J. T. Hill, T. T. Le, M. Darveniza and T. K. Saha, "A Study of Degradation of Cellulosic Insulation Materials in a Power Transformer, Part 1: Molecular Weight Study of Cellulose Insulation Paper", *J. Polymer Degradation and Stability*, Vol. 48, pp. 79-87, 1995.
- [2] G. Csepes, I. Hamos, R. Brooks and V. Karius, "Practical foundations of the RVM (recovery voltage method for oil/paper insulation diagnosis)", *IEEE Conf. Electr. Insul. Dielectr. Phenomena (CEIDP)*, Vol. 1, pp. 345-355, 1998.
- [3] E. Ildstad, U. Gafvert and P. Tharning, "Relation between Return Voltage and Other Methods for Measurements of Dielectric Response", *IEEE Intern. Sympos. Electr. Insul. (ISEI)*, USA, pp.25-28, 1994.
- [4] T. K. Saha, D. J. T. Hill, Z. T. Yao, G. Yeung and M. Darveniza, "The Application of Interfacial Polarization Spectra for Assessing Insulation Condition in aged Power Transformers", *CIGRE session, Paris*, Paper No. 12-202, 1998.
- [5] J.J. Alff, Vahe Der. Houhanessian, W.S. Zaengl and A.J. Kachler, "A Novel, Compact Instrument for the Measurement and Evaluation of Polarisation/Depolarisation Currents Conceived for On-Site Diagnosis of Electric Power Apparatus", *IEEE Intern. Sympos. Electr. Insul.(ISEI)*, USA, pp.161-167, 2000.
- [6] T. K. saha and P. Purkait, "Some Precautions for the Field Users of PDC Measurement for Transformer Insulation Condition Assessment", *IEEE Power Engineering Society General meeting, Toronto, Ontario, Canada*, 13-17 July 2003.
- [7] V. Der Houhanessian and W. S. Zaengl, "Time domain measurements of dielectric response in oil-paper insulation systems", *IEEE Intern. Sympos. Electr. Insul.(ISEI)*, Vol. 1, pp. 47-52, 1996.
- [8] V. Der Houhanessian, *Measurement and Analysis of Dielectric Response in Oil-Paper Insulation Systems*, PhD thesis, Swiss Federal Institute of Technology Zurich, 1998.
- [9] A. K. Jonscher, *Dielectric Relaxation in Solids*, Chelsea Dielectric Press, 1983.
- [10] U. Gafvert, L. Adeen, M. Tapper, P.Ghasemi and B. Jonsson, "Dielectric Spectroscopy in Time and Frequency Domain Applied to Diagnostics of Power Transformers", *IEEE Intern. Conf. Properties and Applications of Dielectric Materials, China*, pp.825-830, 2000.
- [11] M. Darveniza, D. J.T. Hill, T.T.Le and T.K.Saha, "Investigations into Effective Methods for Assessing the Condition of Insulation in Aged Power transformers", *IEEE Trans. Power delivery*, Vol 13, pp.1214-1223, 1998.
- [12] D. H. Shroff and A. W. Stannett, "A Review of Paper Aging in Power Transformers", *IEE Proc.*, Vol. 132, Pt. C, pp. 312-319, 1985.
- [13] P. J. Burton, M. Carballeira, M. Duval, C.W. Fuller, J. Graham, Ade Pablo, J. Samat and E. Spicar, "Applications of Liquid Chromatography to the Analysis of Electrical Insulating Materials", *Proc. CIGRE Conf.*, Paris, Paper No. 15-08, pp. 1-12, 1988.
- [14] T. K. Saha, M. Darveniza, D. J. T. Hill and T. T. Le, "Electrical and Chemical Diagnostics of Transformers Insulation. Part-A. Aged Transformer Samples", *IEEE Trans. Power Delivery*, Vol. 12, pp. 1547-1554, 1997.
- [15] A. M. Emsley and G. C. Stevens, "Review of Chemical Indicators of Degradation of Cellulosic Electrical Paper Insulation in Oil-Filled Transformers", *IEE Proc.-Sci., Measurement and Technology*, Vol.141, pp. 324-334, 1994.
- [16] M. Ali, C. Eley, A. M. Emsley, R. Heywood and X. Xaio, "Measuring and Understanding the Ageing of Kraft Insulating Paper in Power Transformers", *IEEE Electr. Insul. Mag.*, Vol. 12, No. 3, pp. 28-34, 1996.
- [17] A.M. Emsley, M Ali and R. J. Heywood, "A size exclusion chromatographic study of polymer degradation", *Polymer J.*, Vol. 41, No. 24, pp. 8513-8521, 2000,
- [18] A.M. Emsley and R.J. Heywood, "Computer modelling of the degradation of linear polymers", *Polymer Degradation and Stability*, Vol. 49, pp. 145-149, 1995.
- [19] J. L. Ekmanis, "Gel permeation chromatographic analysis of cellulose", *Conf. GPC Analysis of Cellulose. Paper 251*, Pittsburgh, Atlanta City, NJ, USA, 1986.
- [20] M. Guita, O. Chiantore and M. P. Ludo, "Monte-Carlo simulations of polymer degradations. 1. Degradations without volatilization", *Macromolecules J.*, Vol. 23, pp. 87-92, 1990.
- [21] P. J. Baird, H. Herman, G. C. Stevens and P. N. Jarman, "Non-destructive measurement of the degradation of transformer insulating paper", *IEEE Trans. Dielectr. Electr. Insul.*, Vol. 13, pp. 309-318, 2006.
- [22] P. J. Baird, H. Herman, G. C. Stevens and P. N. Jarman, "Spectroscopic measurement and analysis of water and oil in transformer insulating Paper", *IEEE Trans. Dielectr. Electr. Insul.*, Vol. 13, pp. 293-308, 2006.

- [23] P. J. Baird, H. Herman and G. C. Stevens, "Non-destructive Condition Assessment of Insulating Materials in Power Transformers", Intern. Sympos. Electrical Insulating Materials, Vol. 2, pp. 425-428, 2005.
- [24] D. Linhjell, L. Lundgaard and U. Gafvert, "Dielectric response of mineral oil impregnated cellulose and the impact of aging", IEEE Trans. Dielectr. Electr. Insul., Vol. 14, pp. 156-169, 2007.
- [25] T. K. Saha, Z. T. Yao, T. T. Le, M. Darveniza and D. J. T. Hill, "Investigation of Interfacial Polarisation Spectra Parameters for Accelerated Aged Oil-paper Insulation and its Correlation with Molecular Weights and Furan Compounds", CIGRE, Paris, paper No 15-201, 2000.
- [26] T.K Saha, M Darveniza, Z. T. Yao, D. J. T. Hill and G. Yeung, "Investigating the Effects of Oxidation and Thermal Degradation on Electrical and Chemical Properties of Power Transformers Insulation ", IEEE Trans. Power Delivery, Vol. 14, pp. 1359-1367, 1999.
- [27] Z. T. Yao and T. K. Saha, "Separation of Ageing and Moisture Impacts on Transformer Insulation Degradation by Polarization Measurements", CIGRE, Paris, Paper No. 15-304, 2002.
- [28] G. Frimpong, U. Gafvert and J. Fuhr, "Measurement and Modeling of Dielectric Response of Composite Oil/Paper Insulation", IEEE 5th Intern. Conf. Properties and Applications of Dielectric Materials, Vol. 1, pp. 86-89, 1997.
- [29] T. K. Saha and P. Purkait, "Investigation of polarisation and depolarisation current measurements for the assessment of oil-paper insulation of aged transformers", IEEE Trans. Dielectr. Electr. Insul., Vol. 11, pp. 144-154, 2004.
- [30] IEC Standard 60093, "Methods of Test for Volume Resistivity and Surface Resistivity of Solid Electrical Insulating Materials", International Electrotechnical Commission. 1980.
- [31] J. D. Cosgrove, B. C. Head, S. G. Graham, J. O. Warwicker and T. J. Lewis, "A GPC study of cellulose degradation", *Cellulose and its derivatives, 1st ed.* Chichester: Horwood, p. 143, 1985.
- [32] R. Evans and A.F.A Wallis, "Cellulose Molecular Weights Determined by Viscometry", J. Appl. Polymer Sci., Vol. 37, pp. 2331-2340, 1989.
- [33] T. T. Le, D. J. T. Hill and M. Darveniza, "Ageing of Transformer Insulation Paper", J. Macromolecular Sci., pp. 1885-1895, 1996.
- [34] T. V. Oommen, "Moisture Equilibrium Charts for Transformer Insulation Drying Practice", IEEE Trans. Power App. Syst., Vol. PAS-103, no. 10, pp. 3063-3067, 1984.
- [35] ASTM D 3277 standard, "Standard Test Methods for Moisture Content of Oil-Impregnated Cellulosic Insulation", 1995.
- [36] A. Kuechler, F. Huellmandel, K. Boehm, C. Neumann, N. Koch, K. Loppach, C. Krause and J.-J. Alff, "Condition assessment of aged transformer bushing insulations", Paper A2-104, CIGRE, Paris, France, pp. 1-10.2006.
- [37] A.M. Emsley, X Xiao, R. J. Heywood and M Ali, "Degradation of cellulosic insulation in power transformers. Part 3: effects of oxygen and water on ageing in oil", IEE Proceedings - Science, Measurement and Technology, vol. 147, no. 3, 2000, pp. 115-119.
- [38] J. Fabre and A. Pichon, "Deteriorating processes and products of paper in oil. Application to transformers", CIGRE, Paper 137, pp. 1-18, 1960.
- [39] S. M. Gubanski, P. Boss, P. G. Csepes, V. Der Houhanessian, J. Filippini, P. Guuinic, U. Gafvert, V. Karius, J. Lapworth, G. Urbani, P. Werelius, and W. Zaengl, "Dielectric response methods for diagnostics of power transformers", IEEE Electrical Insulation Magazine, Vol. 19, No. 3, pp. 12-18, 2003.



**Tapan K. Saha** (SM'97) was born in Bangladesh and immigrated to Australia in 1989. Currently, he is Professor of Electrical Engineering in the School of Information Technology and Electrical Engineering, University of Queensland, Brisbane, Australia. Before joining the University of Queensland, he taught at the Bangladesh University of Engineering and Technology, Dhaka, for three-and half years and then at James Cook University, Townsville, Australia, for two and half years. His research interests include power systems, power quality, and condition monitoring of electrical plants. Dr. Saha is a Fellow of the Institution of Engineers, Australia.



**Prithwiraj Purkait** (M'99) was born in Kolkata, India, in 1973. He received the B.E.E., M.E.E., and Ph.D. degrees from Jadavpur University, Kolkata, in 1996, 1999, and 2002, respectively. He was involved in post-doctoral research in the University of Queensland, Australia during 2002-2003, and for additional research during 2005. He was also a Design Engineer with M/s Crompton Greaves Ltd., Mumbai, India, for one year during 1996-97. Presently he holds the post of Associate Professor and Head, Department of Electrical Engineering Haldia Institute of Technology, Haldia, India. His current research includes transformer insulation condition assessment techniques and advanced signal processing applications in High Voltage Engineering.